

[REDACTED]

From: Fein, Edward K. (JSC-AL)
Sent: Friday, October 17, 2008 10:10 AM
To: Galus, Helen M. (LARC-B2); Rotella, Robert F. (HQ-MA000); Homer, Mark W. (JPL-0910)
Cc: Blackburn, Linda B. (LARC-B2)
Subject: RE: File wrapper for 5,904,724

Got it. Thanks. (I think.)

Have a great weekend, Helen!

-Ed

From: Galus, Helen M. (LARC-B2)
Sent: Friday, October 17, 2008 9:00 AM
To: Rotella, Robert F. (HQ-MA000); Homer, Mark W. (JPL-0910); Fein, Edward K. (JSC-AL)
Cc: Blackburn, Linda B. (LARC-B2); Galus, Helen M. (LARC-B2)
Subject: FW: File wrapper for 5,904,724

Dear Bob, Mark and Ed,

Here is the file wrapper for the Margolin Patent 5,904,724 - "Method and Apparatus for Remotely Piloting an Aircraft" (I also have the file wrapper for the synthetic vision technology). It apparently was prepared by ReedFax

Please let me know if you have any trouble opening or receiving all of the attachments (there should be eight of them).

Thanks,
Helen

Helen M. Galus
Patent Attorney
Office of Chief Counsel
NASA Langley Research Center

[REDACTED]

[REDACTED]

b(6)

[REDACTED]

This email message is for the sole use of the intended recipient(s) and may contain confidential and/or privileged information. NOTICE: Any review, use, disclosure or distribution by persons or entities other than the intended recipient(s) is prohibited. If you are not the intended recipient, please contact the sender by reply and destroy all copies of the original message. Thank you.

United States Patent [19]

[11] Patent Number: **5,904,724**

Margolin

[45] Date of Patent: **May 18, 1999**

[54] **METHOD AND APPARATUS FOR REMOTELY PILOTING AN AIRCRAFT**
 [76] Inventor: **Jed Margolin**, 3570 Pleasant Echo, San Jose, Calif. 95148

5,406,286	4/1995	Tran et al.	342/13
5,446,666	8/1995	Bauer	364/434
5,552,983	9/1996	Thornberg et al.	364/424.027
5,581,250	12/1996	Khviliviky	340/961

OTHER PUBLICATIONS

Lyons, J.W., "Some Navigational Concepts for Remotely Piloted Vehicles", AGARD Conference Proceed, n 176, Med. Accur. Low Cost Navig. at Avion, Panel Tec. Meeting, 5-1-5-15, Sep. 1975.

"US GeoData Digital Line Graphs", U.S. Dept. of the Interior, U.S. Geol. Surv. Earth Sci. Info Ctr. (Factsheet) Jun. 1993.

"US GeoData Digital Elevation Models", U.S. Dept. of the Interior, U.S. Geol. Surv. Earth Sci. Info Ctr. (Factsheet) Jun. 1993.

Shifrin, Carole A., "Gripen Likely to Fly Again Soon," *Aviation Week & Space Technology*, Aug. 23, 1993, pp. 72-73.

Primary Examiner—Tan Q. Nguyen

Attorney, Agent, or Firm—Blakely, Sokoloff, Taylor and Zafman LLP

[21] Appl. No.: **08/587,731**
 [22] Filed: **Jan. 19, 1996**
 [51] Int. Cl.⁶ **G06F 165/00; H04N 7/18**
 [52] U.S. Cl. **701/120; 701/2; 701/24; 244/189; 244/190; 348/114**
 [58] Field of Search 364/423.099, 424.012, 364/424.013, 424.021, 424.022, 449.2, 449.7, 460, 439, 424.028; 340/825.69, 825.72, 967, 989, 991, 992, 993; 244/189, 190, 181, 17.13, 3.11, 3.15; 348/42, 51, 113, 114, 117, 123, 143; 382/154; 395/118, 119, 125

[56] **References Cited**

U.S. PATENT DOCUMENTS

3,742,495	6/1973	Diamantides	342/64
3,795,909	3/1974	Vehrs, Jr.	343/7
4,218,702	8/1980	Brocard et al.	348/144
4,405,943	9/1983	Kanaly	358/133
4,467,429	8/1984	Kendig	343/433
4,660,157	4/1987	Beckwith et al.	345/421
4,739,327	4/1988	Konig et al.	342/26
4,760,396	7/1988	Barney et al.	342/65
4,835,532	5/1989	Fant	382/284
4,855,822	8/1989	Naredra et al.	364/423.099
4,964,598	10/1990	Berejik et al.	244/190
5,015,187	5/1991	Lord	364/462
5,072,396	12/1991	Fitzpatrick et al.	364/450
5,086,396	2/1992	Waruszewski, Jr.	364/454
5,155,683	10/1992	Rahim	364/424.029
5,179,638	1/1993	Dawson et al.	395/125
5,240,207	8/1993	Eiband et al.	364/423.099
5,257,347	10/1993	Busbridge et al.	395/129
5,266,799	11/1993	Steinitz et al.	324/330
5,272,639	12/1993	McGuffin	364/449
5,335,181	8/1994	McGuffin	364/443
5,381,338	1/1995	Wysocki et al.	348/116

[57] **ABSTRACT**

A method and apparatus that allows a remote aircraft to be controlled by a remotely located pilot who is presented with a synthesized three-dimensional projected view representing the environment around the remote aircraft. According to one aspect of the invention, a remote aircraft transmits its three-dimensional position and orientation to a remote pilot station. The remote pilot station applies this information to a digital database containing a three dimensional description of the environment around the remote aircraft to present the remote pilot with a three dimensional projected view of this environment. The remote pilot reacts to this view and interacts with the pilot controls, whose signals are transmitted back to the remote aircraft. In addition, the system compensates for the communications delay between the remote aircraft and the remote pilot station by controlling the sensitivity of the pilot controls.

20 Claims, 7 Drawing Sheets

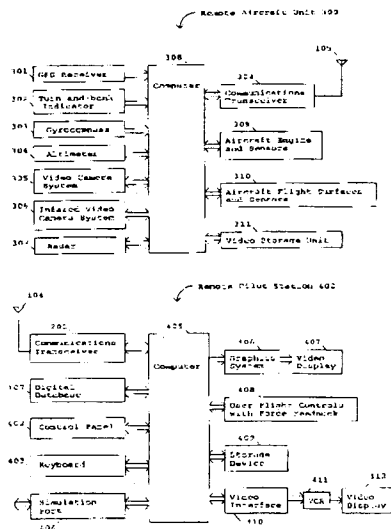

01998

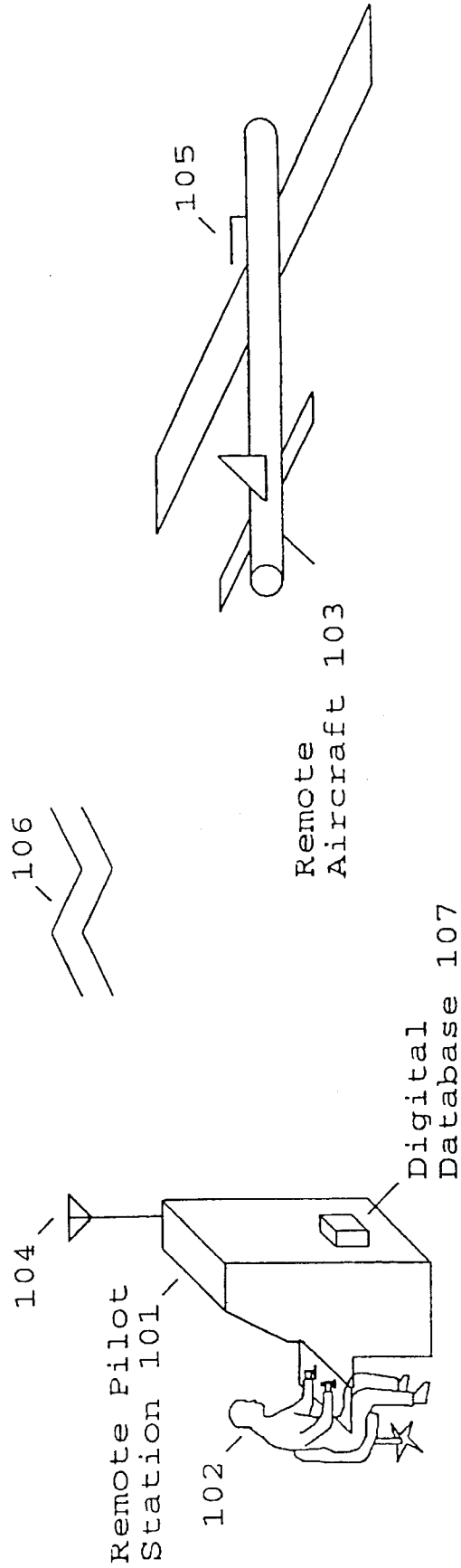

Fig. 1

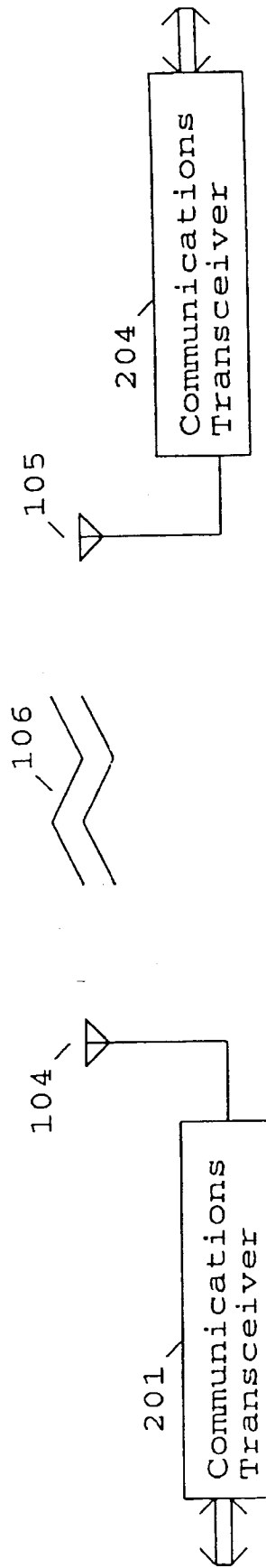

Fig. 2

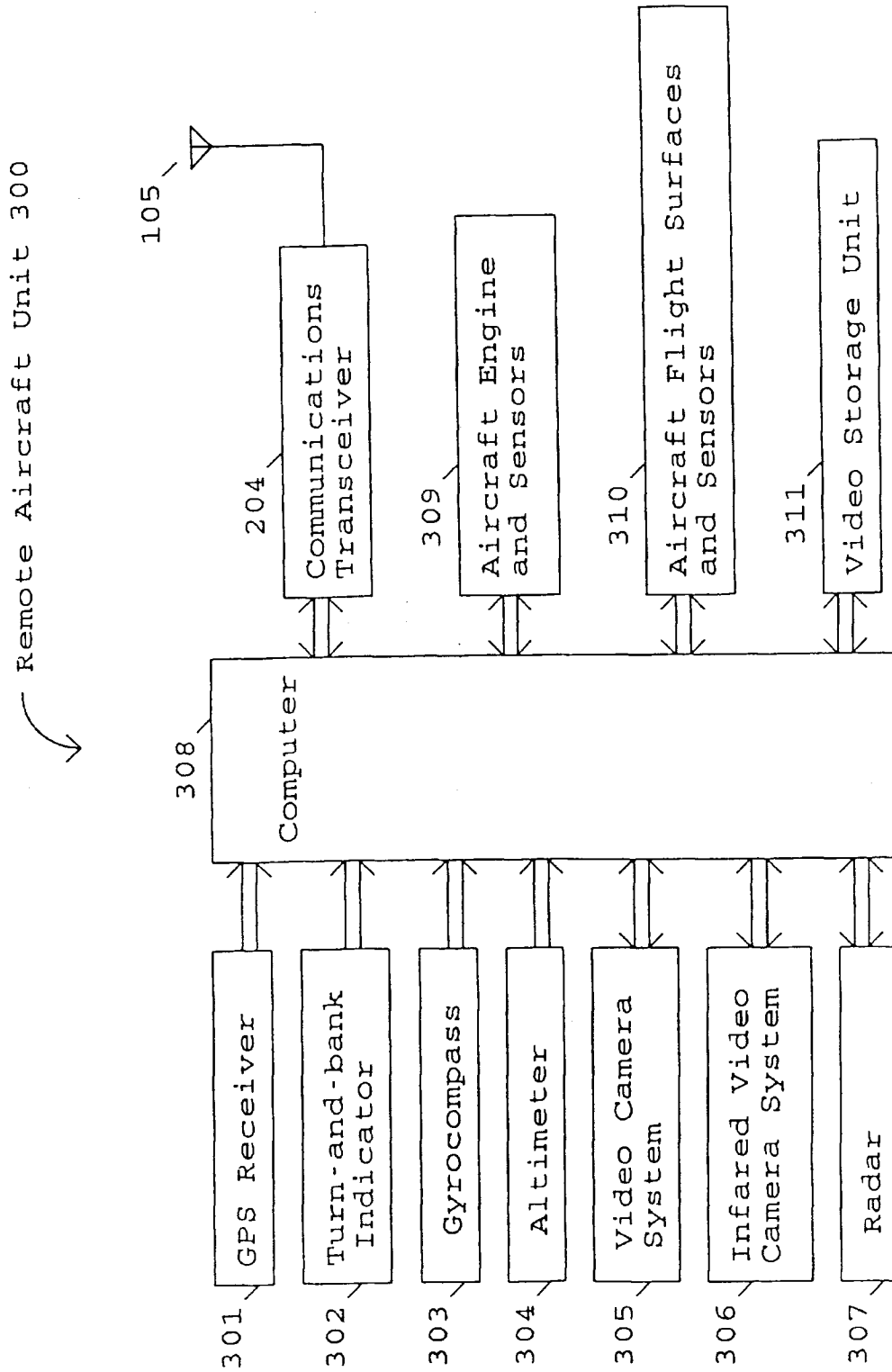

Fig. 3

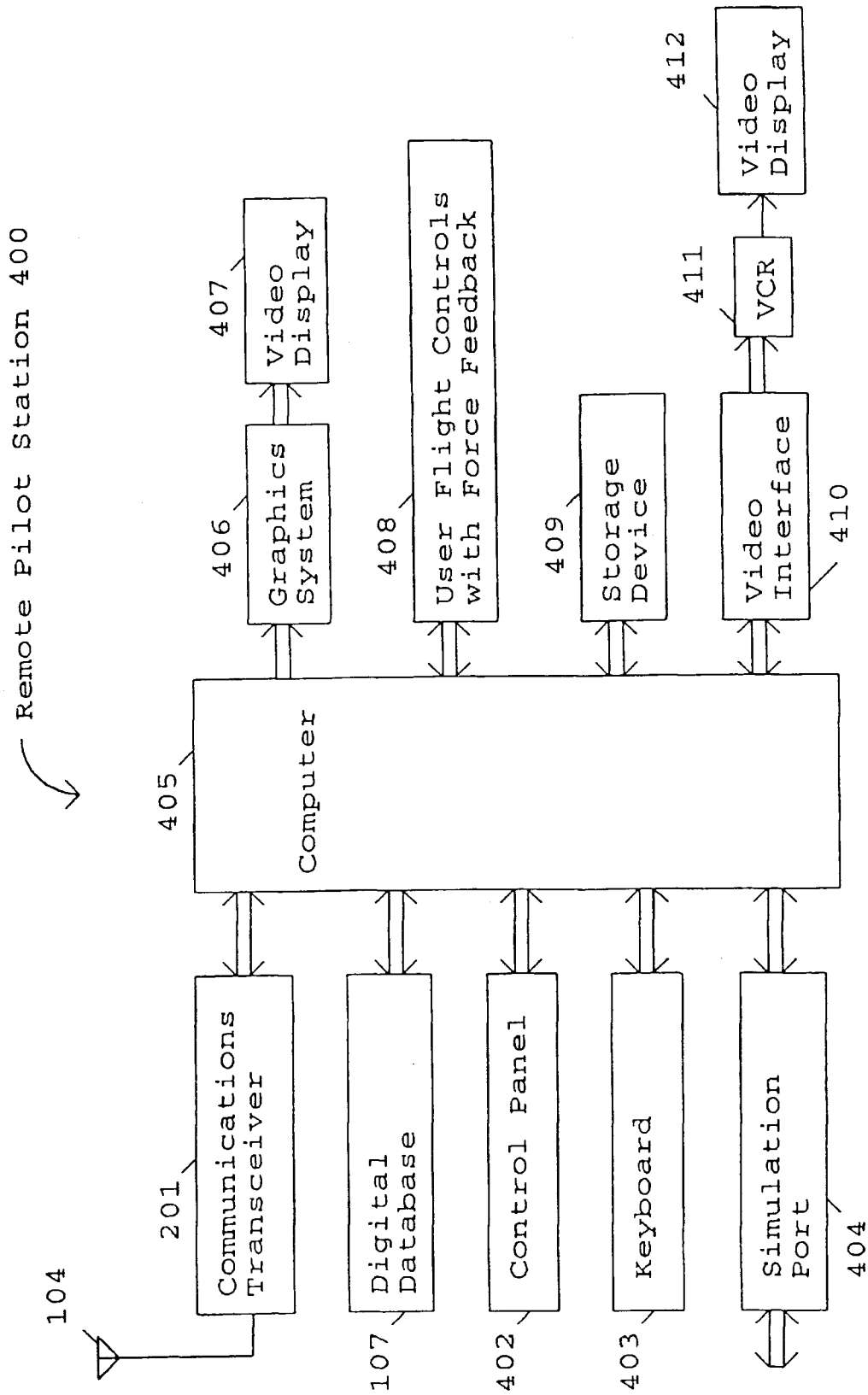

Fig. 4

02002

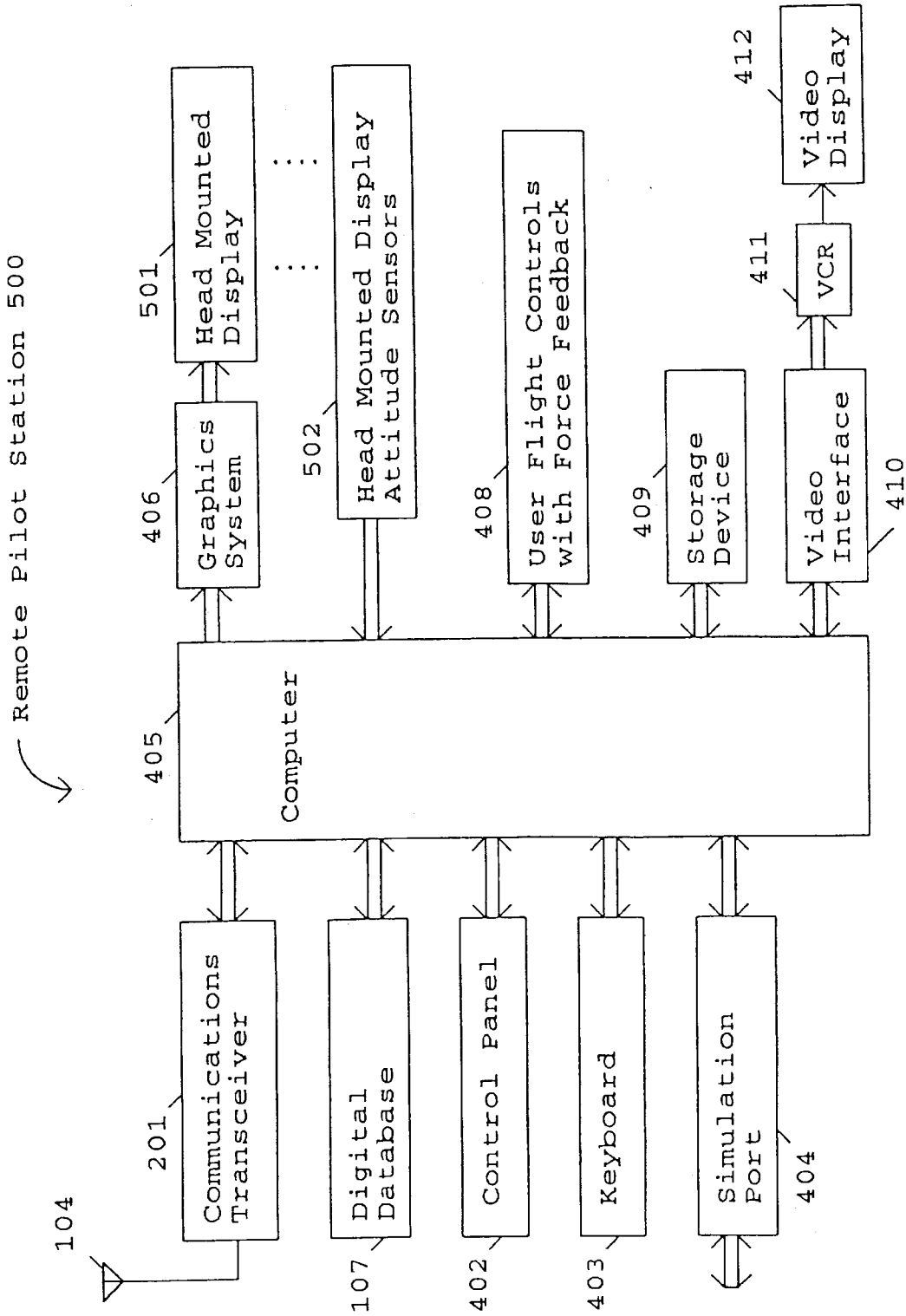

Fig. 5

02003

Remote Aircraft Simulator 600

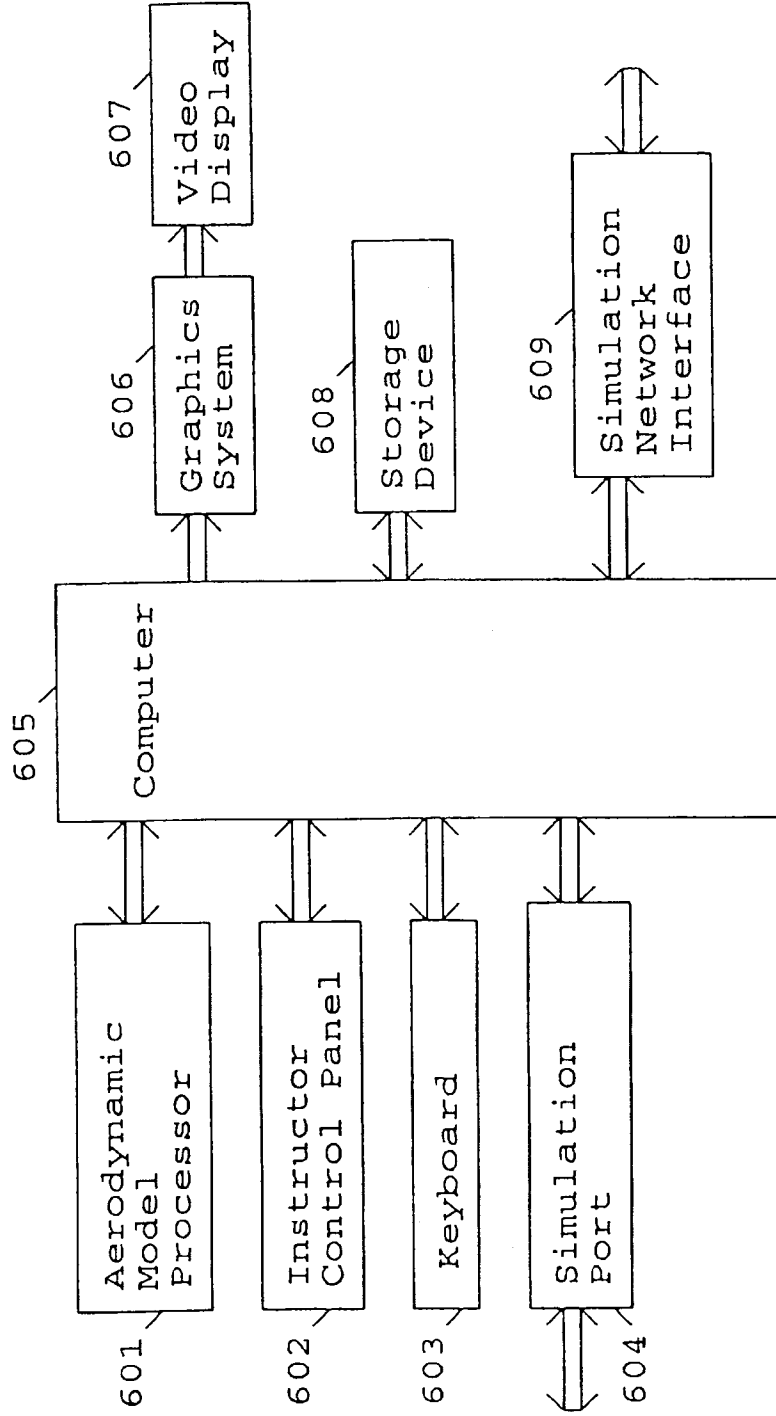

Fig. 6

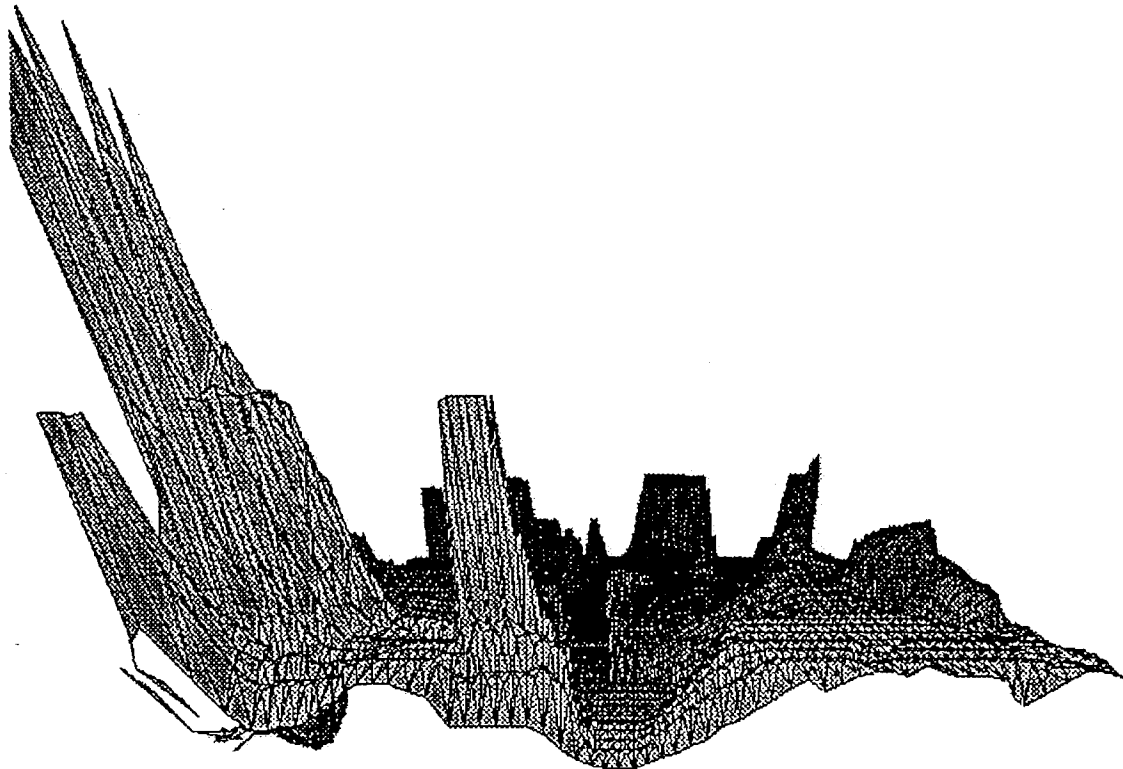

Figure 7

METHOD AND APPARATUS FOR REMOTELY PILOTING AN AIRCRAFT

BACKGROUND OF THE INVENTION—CROSS REFERENCES TO RELATED APPLICATIONS

“Pilot Aid Using a Synthetic Environment”, Ser. No. 08/274,394 filed Jul. 11, 1994. “Digital Map Generator and Display System”, Ser. No. 08/543,590, filed Oct. 16, 1995.

1. Field of Invention

This invention relates to the field of remotely piloted vehicles (RPVs) and unmanned aerial vehicles (UAVs).

2. Discussion of Prior Art

RPVs can be used for any number of purposes. For example, there is a large organization that promotes the use of remote controlled planes. Certain RPVs are controlled by viewing the plane with the naked eye and using a hand held controller to control its flight. Other RPVs are controlled by a remote pilot using simple joysticks while watching the video produced by a camera in the remote aircraft. This camera is also used to produce the reconnaissance video. There are tradeoffs involving the resolution of the video, the rate at which the video is updated, and the bandwidth needed to transmit it. The wider the bandwidth the more difficult it is to secure the signal. The freedom to balance these tradeoffs is limited because this video is also used to pilot the aircraft and must therefore be updated frequently.

Certain UAVs are preprogrammed to follow a predetermined course and lack the flexibility to deal with unexpected situations.

The 1983 patent to Kanaly (U.S. Pat. No. 4,405,943) shows a control and communications system for a remotely piloted vehicle where an oculometer determines where the remote operator is looking and signals the remote vehicle to send the high resolution imagery corresponding to the area around where the remote operator is looking and low resolution imagery corresponding to the remote operator's peripheral vision. The objective is to minimize the bandwidth of the information transmitted to the remote operator.

SUMMARY

A method and apparatus is described that allows a remote aircraft to be controlled by a remotely located pilot who is presented with a synthesized three-dimensional projected view representing the environment around the remote aircraft. According to one aspect of the invention, a system is used that includes an aircraft and a remote pilot station.

The aircraft uses a communications link to send its location, attitude, and other operating conditions to the remote pilot station. The remote pilot station receives the data and uses a database describing the terrain and manmade structures in the remote aircraft's environment to produce a 3D view of the remote aircraft environment and present it to the remote human pilot.

The remote pilot responds to the information and manipulates the remote flight controls, whose positions and forces are transmitted to the remote aircraft. Since the amount of data is small, it can be readily secured through encryption and spread spectrum techniques.

Also, because the video reconnaissance cameras are no longer needed to remotely pilot the aircraft there is great flexibility in their use. To minimize bandwidth and reduce the possibility of being detected, the video data can be sent at a slow update rate. The data can also be stored on the remote aircraft for later transmission. Alternatively, low resolution pictures can be sent in real-time, while the cor-

responding high resolution pictures can be at a later time. The reconnaissance video can even be transmitted through a different communications link than the control data. There may also be more than one reconnaissance camera.

The delay in the control link must be minimized in order that the remote aircraft can be properly flown. The system can measure the link delay and make this information available to the pilot. This delay link measurement can also be used to modify the control software through which the remote pilot flies the remote aircraft. This is to prevent pilot-induced-oscillation.

The computers in the system allow for several modes of operation. For example, the remote aircraft can be instructed to fly to given coordinates without further input from the remote pilot. It also makes it possible to provide computer assistance to the remote pilot. In this mode, the remote flight control controls absolute pitch and roll angles instead pitch and roll rates which is the normal mode for aircraft. In addition, adverse yaw can be automatically corrected so that the resulting control laws make the remote aircraft extremely easy to fly. Because this comes at the expense of being able to put the remote aircraft into unusual attitudes, for complete control of the remote aircraft a standard control mode is provided to give the remote pilot the same type of control that is used to fly a manned aircraft. Since the remote aircraft is unmanned, the remote pilot can subject the remote aircraft to high-G maneuvers that would not be safe for a pilot present in the aircraft.

To facilitate training, a simulated remote aircraft is provided that allows an instructor to set up the training mission and parameters. This is especially useful in giving remote pilots experience flying with different control link delays. In this simulated mode, the system can be further linked to a battlefield simulator such as SIMNET.

In the first embodiment, the remote pilot is provided with a standard video display. Additional display channels can be provided to give the remote pilot a greater field of view. There can even be a display channel to give a rearward facing view.

A second embodiment uses a head mounted display for the remote pilot instead of a standard display. This permits the remote station to be made more compact so that it can be used in a wider variety of installations. An example would be in a manned aircraft flying several hundred miles away.

BRIEF DESCRIPTION OF THE DRAWINGS

The invention may best be understood by referring to the following description and accompanying drawings which illustrate the invention. In the drawings:

FIG. 1 is a general illustration showing a remote pilot at a remote pilot station operating a remote aircraft according to one embodiment of the invention.

FIG. 2 is a block diagram showing the communications link between a remote pilot station and a remote aircraft according to one embodiment of the invention.

FIG. 3 is a block diagram of a remote aircraft according to one embodiment of the invention.

FIG. 4 is a block diagram of a remote pilot station according to one embodiment of the invention.

FIG. 5 is a block diagram of a remote pilot station according to another embodiment of the invention.

FIG. 6 is a block diagram of a remote aircraft simulator used for training remote pilots according to one embodiment of the invention.

FIG. 7 is an example of a three dimensional projected image presented to a remote pilot by a remote pilot station according to one embodiment of the invention.

DETAILED DESCRIPTION

In the following description, numerous specific details are set forth to provide a thorough understanding of the invention. However, it is understood that the invention may be practiced without these specific details. In other instances, well-known circuits, structures and techniques have not been shown in detail in order not to obscure the invention.

A method and apparatus is described that allows a remote aircraft to be controlled by a remotely located pilot who is presented with a synthesized three-dimensional projected view representing the environment around the remote aircraft. Since the video from a reconnaissance camera located on the remote aircraft is not used to pilot the remote aircraft, the amount of data transmitted between the remote aircraft and the remote pilot is small. This provides greater flexibility in how the remote aircraft is used and allows the transmitted data to be made more secure. The remote aircraft may be of any type, for example a remote control plane or helicopter as used by recreational enthusiast.

FIG. 1 is a general illustration showing a remote pilot at a remote pilot station operating a remote aircraft according to one embodiment of the invention. FIG. 1 shows Remote Pilot 102 interacting with Remote Pilot Station 101 and controlling Remote Aircraft 103. Remote Pilot Station 101 and Remote Aircraft 103 respectively include an Antenna 104 and an Antenna 105 for communicating Information 106.

In one embodiment, Information 106 includes status information concerning the status of Remote Aircraft 103 and flight control information for controlling the flight of Remote Aircraft 103. The status information is generated by Remote Aircraft 103 and includes the three dimensional position and the orientation (also termed attitude, and comprising heading, roll, pitch) of Remote Aircraft 103. The status information may also include information concerning the flight surfaces, the engine, an additional altitude reading, etc. Remote Pilot Station 101 uses this status information to retrieve data from a Digital Database 107 which contains a three-dimensional description of terrain and manmade structures over which Remote Aircraft 103 is flying. Based on the three dimensional data retrieved from Digital Database 107, Remote Pilot Station 101 projects a synthesized three-dimensional projected view of the terrain and manmade structures in the vicinity of Remote Aircraft 103. Based on this view of the terrain and manmade structures, the Remote Pilot Station 101, on its own and/or in response to input from Remote Pilot 102, generates and transmits flight control information to Remote Aircraft 103 which adjusts its flight accordingly.

In one embodiment, the Remote Aircraft 103 is a remote controlled plane or helicopter used for recreational purposes. Since remote controlled planes and helicopters tend to be small in size, the circuitry in such remote aircraft to generate and receive Information 106 is minimized. In such systems, the Remote Pilot Station 101 may be implemented by including additional attachments to an existing portable computer. This allows the user to easily transport the remote aircraft and pilot station to an appropriate location for flight.

FIG. 2 is a block diagram showing a bi-directional communications link between a remote pilot station and a remote aircraft according to one embodiment of the invention. FIG. 2 shows Communications Transceiver 201 coupled to Antenna 104 of Remote Pilot Station 101, as well as Communications Transceiver 204 coupled to Antenna 105 of Remote Aircraft 103. In addition, FIG. 2 shows Information 106 being communicated between Antenna 104 and Antenna 105.

FIG. 3 is a block diagram of a remote aircraft unit used in the remote aircraft according to one embodiment of the invention. FIG. 3 shows Remote Aircraft Unit 300 including Computer 308 coupled to GPS Receiver 301, Turn-and-bank Indicator 302, Gyrocompass 303, Communications Transceiver 204, Aircraft Engine and Sensors 309, and Aircraft Flight Surfaces and Sensors 310. GPS Receiver 301 receives signals from the satellites that make up the global positioning system (GPS) and calculates the aircraft's position in three dimensions. Turn-and-bank Indicator 302 and Gyrocompass 303 provide the aircraft's orientation which comprises heading, roll, and pitch. This data is sent to Computer 308 for transformation into the previously described status information. Computer 308 transmits this status information to Communications Transceiver 204 which produces a radio signal and supplies it to Antenna 105.

The Aircraft Engine and Sensors 309 are coupled to control the aircraft's engine, while the Aircraft Flight Surfaces and Sensors 310 are coupled to control the aircraft's flight surfaces. The flight control information is received from the remote pilot station by Computer 308 through Antenna 105 and Communications Transceiver 204. This flight control information is processed by Computer 308 into the necessary signals for transmission to Aircraft Engine and Sensors 309 and Aircraft Flight Surfaces and Sensors 310 to control the aircraft's engine and flight surfaces, respectively. The operation of the aircraft's flight control surfaces will be later described with reference to FIG. 4.

In order to protect against ECM, the communications link between the Remote Pilot Station 101 and the Remote Aircraft 103 may be secured. While any number of different techniques may be used to secure this link, in one embodiment Computer 308 is implemented to encrypt/decrypt the data transmitted and Communications Transceiver 204 is implemented to use spread spectrum techniques.

Computer 308 may optionally be coupled to Altimeter 304, Video Camera System 305, Infrared Video Camera System 306, Radar 307, and/or Video Storage Unit 311. Altimeter 304 provides an output of the aircraft's altitude as a safety check in the event GPS Receiver 301 malfunctions. Thus, this additional altitude reading may also be transmitted to Remote Pilot Station 101 as part of the status information.

Video Camera System 305 is controlled by Computer 308 which determines where the camera is pointing as well as focusing and the zoom factor. The video produced by the camera is not used by the remote pilot for flying the remote aircraft, so there is more flexibility in using the video. As a result, any number of techniques can be used for receiving the images captured by Video Camera System 305. As examples:

1. High resolution, high update images may be sent back in real-time through the Communications Link, when the high bandwidth needed can be tolerated.
2. High resolution, low update images may be sent back in real-time through the Communications Link to reduce the bandwidth.
3. The video may be recorded in Video Storage Unit 311 for later transmission.
4. The video may be transmitted through a separate communications link.
5. There may be multiple video cameras.

Infrared Video Camera System 306 is similar to Video Camera System 305 and has the same operating modes.

Radar 307 in Remote Aircraft 103 may be passive or active. It may scan a particular pattern or it may track a

selected object. Radar 307 may consist of several Radar units. The information from Radar 307 is processed by Computer 308 so that only the desired information is transmitted over the communication link to the Remote Pilot Station 101 for display.

FIG. 4 is a block diagram of a remote pilot station according to one embodiment of the invention. FIG. 4 shows a Remote Pilot Station 400 including a Computer 405 coupled to Communications Transceiver 201, Digital Database 107, Graphics System 406, User Flight Controls with Force Feedback 408, and a Storage Device 409. The Storage Device 409 represents one or more mechanisms for storing data. For example, the Storage Device 409 may include read only memory (ROM), random access memory (RAM), magnetic disk storage mediums, optical storage mediums, flash memory devices, and/or other machine-readable mediums. Of course, Digital Database 107 may be stored in one or more machine-readable mediums and/or in Storage Device 409.

As previously described, Antenna 104 receives the radio signals transmitted by Remote Aircraft 103 representing the status information of Remote Aircraft 103. These radio signals are transformed by Communications Transceiver 201 and sent to Computer 405. Communications Transceiver 201 is set to the same mode as Communications Transceiver 204, so that if, for example, spread spectrum techniques are used, the signal will be transparently received. Computer 405 recovers the data (de-encrypting, if required) so that the data communications from Computer 308 in the Remote Aircraft to Computer 405 in the Remote Pilot Station is transparent. Thus, the bi-directional communications link comprises the combination of Communications Transceiver 201, Antenna 104, Antenna 105, and Communications Transceiver 204.

As previously described, the status information received by Computer 405 includes the three dimensional position and the orientation of Remote Aircraft 103. The status information may also include information concerning the flight surfaces, flight sensors, the engine, an additional altitude reading, etc. Computer 405 uses this status information to retrieve data from Digital Database 107 which contains a three-dimensional description of terrain and man-made structures over which Remote Aircraft 103 is flying. The composition and creation of the Digital Database 107 is further described later. Based on the three dimensional data retrieved from Digital Database 107, Computer 405 performs the mathematical operations to transform and project the three dimensional data to generate video data representing a synthesized three-dimensional projected view of the terrain (and, if desired, manmade structures) in the vicinity or environment of Remote Aircraft 103. This video data is transmitted to Graphics System 406, which displays the synthesized three-dimensional projected view on Video Display 407.

Since the image is generated from the digital database, virtually any image of the environment of the Remote Aircraft 103 can be generated. As examples, the pilot may select the environment to be: 1) a simulated image of what would be seen out of the cockpit of a manned aircraft on a similar flight path; 2) a simulated image of what would be seen when looking in any direction (e.g., backwards, out a side window, etc.); 3) a simulated image of what would be seen if a camera were tailing the remotely piloted aircraft; etc. In addition, the simulated image may be set to any magnification. Thus, the phrase environment of Remote Aircraft 103 is intended to include any image generated with reference to the remote aircraft's position.

The User Flight controls with Force Feedback 408 are used by the remote pilot to input flight path information. The User Flight Controls may be of any number of different types, some of which are further described later herein. The status information received by Computer 405 also includes information received from Aircraft Flight Surfaces and Sensors 310. This information is used to actuate force feedback circuitry in User Flight Controls With Force Feedback 408. Remote Pilot 102 observes the synthesized three-dimensional environment displayed on Video Display 407, feels the forces on User Flight Controls With Force Feedback 408 and moves the controls accordingly. This flight control information is sent through the communications link, to Computer 308, and is used to control the aircraft flight surfaces in Aircraft Flight Surfaces and Sensors 310. Remote Pilot 102 also receives data from Aircraft Engine and Sensors 309 through the communications link and is able to send data back to control the engine.

Flight Control

To illustrate the operation of the remote aircraft, a fixed-wing airplane will be described as an example. However, the basic principles apply to other types of aircraft as well. The basic control surfaces of an airplane consist of the ailerons, the horizontal elevators, and the rudder. The ailerons are moved differentially (one up, one down) to rotate the airplane around its roll axis; the horizontal elevators cause the airplane to rotate around its pitch axis; and the rudder causes the airplane to rotate around its yaw axis.

When the ailerons are used to modify the lift characteristics of the wings, one wing creates more lift while the other wing creates less lift. This also changes the drag characteristics of the wings and results in a yaw force that is opposite to the yaw force that results from the tail section causing the airplane to weather-cock into the relative wind. It is this yaw force caused by the airplane weather-cocking into the relative wind that causes a banked airplane to turn. The opposite yaw force produced by using the ailerons is called adverse yaw; the rudder control is used to counteract this force to produce a coordinated turn.

The simplest type of flight control consists of a joystick and a set of rudder pedals. The controls are directly connected to the flight control surfaces. With a joystick, moving the stick left and right moves the ailerons, while moving the stick forward and backward moves the horizontal elevators. The rudder is controlled by two foot pedals, one for each foot, that are mounted on a common shaft and hinged in the middle like a seesaw. Pressing one foot pedal forward causes the other foot pedal to move backward and causes the rudder to also move in one direction. Pressing the other foot pedal causes it to move forward and the opposite pedal to move backward and causes the rudder to move in the opposite direction.

An alternative to the joystick is the control yoke which consists of a wheel attached to a shaft that moves in and out of the control housing. Turning the wheel clockwise or counterclockwise moves the ailerons; moving the wheel shaft in and out moves the horizontal elevators. The rudder pedals are the same as those used with a joystick.

In order to aid in a description of remote aircraft operation, it is thought worthwhile to first describe the operation of non-remotely piloted vehicles. Non-remotely piloted vehicles can be operated in one of two ways (also termed as flight control modes); direct control or computer control (also termed as computer mediated).

Direct Control Non-Remotely Piloted Vehicles

When the flight controls are connected directly to the control surfaces the result is a second order system. Using

the joystick as an example, moving the joystick left or right establishes a roll rate. The airplane continues to roll until the joystick is returned to the center position, after which the airplane remains in the bank angle thus established. The foot pedals are used to counteract the adverse yaw as previously described. Moving the joystick forward or backward establishes a pitch rate. The airplane continues to pitch until the joystick is returned to the center position, after which the airplane remains in the pitch angle thus established. Both the roll rate and the pitch rate are subject to the limits of the airplane's design.

Since the joystick is directly connected to the control surfaces, the aerodynamic forces on the control surfaces are transmitted back to the pilot, giving him or her valuable feedback on how the airplane is flying.

The successful operation of the second order system with the pilot in the loop depends on several factors such as the area and placement of the control surfaces, how much the control surfaces move in response to the movement of the pilot controls, and how long the airplane takes to respond to changes of the control surfaces. The total system characteristics also depend on the reaction time of the pilot. If the resulting system is poorly designed it may be unstable, which means it may not be possible for a human pilot to fly it safely. An example of an unstable system is where the pilot desires to perform a gentle roll to the right and so moves the joystick to the right, the airplane's roll rate is faster than the pilot desires so he/she attempts to compensate by moving the joystick to the left, the airplane rolls left at a rate that is faster than the pilot desires so he/she moves the joystick to the right, and so on, with the pilot constantly overcorrecting and with the aircraft's rolling motions constantly getting larger and larger until the aircraft gets into a condition from which it may not be possible to recover, (e.g., spinning into the ground). The type of loss of control described is usually referred to as 'pilot induced oscillation' and although it may be caused by an inexperienced or inattentive pilot, it is more often caused by poor airplane design. Therefore, new airplane designs are extensively tested to make sure they can be safely flown. Examples of airplanes that use direct control of the control surfaces (Direct Control Second Order Systems) are the Cessna 150 and the Piper Cub.

Computer Mediated Non-Remotely Piloted Vehicles

Computer mediated control systems use a computer between the pilot controls and the control surfaces. The pilot controls are read by the computer, the data are modified in a particular way, and the computer sends control signals to the control surfaces. The computer may also sense the forces on the control surface and use it to control force feedback to the pilot controls. This type of computer mediated control may be used to fly an airplane that would otherwise be unstable, such as the F16 or the F117. Aircraft such as the F16 and F117 are also second order systems because the position of the pilot's joystick represents rate of rotation.

There are risks inherent in a computer mediated system. Although the program can be simulated extensively before using it in an actual airplane, the computer program may be quite large and therefore difficult to simulate under all possible conditions. An example of this is the Swedish JAS 39 Gripen Fighter. Despite extensive simulation of the flight control system, during a test flight a Gripen crashed due to "... the flight control system's high amplification of stick commands combined with the pilot's" large, rapid stick movements." The pilot had entered a low-speed high-banked turn at a 280 meter altitude with lit afterburners and

was leaving the turn when his actions led to 'pilot-induced oscillation'. (Aviation Week & Space Technology, Aug. 23, 1993, pages 72-73).

Having described techniques for operating non-remotely piloted vehicles, the Fight Control Modes for RPVs will be described.

Second Order RPV Flight Control Mode

A second order control system for an RPV is inherently computer mediated because the remote pilot must interact through two computers: the computer in the remote aircraft and the computer in the remote pilot station.

Flying an RPV is further complicated because there are additional time delays in the loop. The computer in the remote aircraft must first determine the aircraft's position and orientation. The additional processing for transmitting a secure signal by encryption and/or spread spectrum techniques may create additional delays. Transmission delay of signals between the remote aircraft and remote pilot station is negligible for a direct path. However, if the signals are relayed through other facilities the delay time may be appreciable, especially if an orbiting satellite is used. There are additional delays in the remote pilot station as the remote aircraft's position and orientation are used to transform the data from the digital database to present the pilot with the synthesized 3D projected view from the remote aircraft. In one embodiment, the RPV system measures the various delays and modifies the control laws used by the computer in the remote pilot aircraft and in the feedback provided by the computer in the remote pilot station to the remote pilot. For example, the computer may adjust the sensitivity of the User Flight Controls 408 according to the delay (e.g., as the delay increases, the computer will decrease the sensitivity of the flight controls). The system also displays the measured delay to the remote pilot.

First Order RPV Flight Control Mode

The stability of the flight control system, and thus the flyability of an RPV, can be improved considerably by using a first order system. In one embodiment of such a first order system the position of the remote pilot's joystick represents an angle relative to the horizon, instead of representing a rate of rotation as in a second order system. The position of the joystick is transmitted to the computer in the remote aircraft which moves the control surfaces as required to place the remote aircraft in the requested orientation. The control system in the remote aircraft is still a second order system but the delays in the communications link and the remote pilot station are no longer a part of the system's loop.

When a joystick is centered, the remote aircraft will fly straight and level. When the joystick is to the right of center the remote aircraft will be in a right banked turn. When the joystick is to the left of center the remote aircraft will be in a left banked turn. When the joystick is backward from center the remote aircraft will be in a pitch up orientation. When the joystick is forward of center the remote aircraft will be in a pitch down orientation.

The amount of bank and pitch permitted depends on the design of the remote aircraft. A high performance remote aircraft will be capable of a greater amount of pitch and bank than will a low performance remote aircraft.

Referring again to FIG. 4, Computer 405 may optionally be coupled to Control Panel 402, Keyboard 403, Simulation Port 404, Video Interface 410, VCR 411, and/or Video Display 412. In one embodiment, Control Panel 402 con-

tains specialized lights, displays, and switches to allow a quicker response to situations than can be provided by Keyboard 403. Control Panel 402 can be arranged to approximate the look and feel of an actual aircraft cockpit. Keyboard 403 allows the remote pilot to select various operating modes. For training purposes, Simulation Port 404 allows the remote pilot station to be connected to a remote aircraft simulator instead of an actual remote aircraft. The remote aircraft simulator will be further described with reference to FIG. 6. Storage Device 409 allows the flight data to be recorded. During playback this previously recorded data is substituted for real-time data from the remote aircraft to replay the mission for analysis. Any video received from any reconnaissance cameras on the Remote Aircraft 103 is converted by Video Interface 410 so that it can be recorded on VCR 411 and displayed on Video Display 412. VCR 411 can also operate in straight-through mode so that the reconnaissance video can be viewed in real time.

FIG. 5 is a block diagram of a remote pilot station according to another embodiment of the invention. FIG. 5 shows Remote Pilot Station 500. Remote Pilot Station 500 is similar to Remote Pilot Station 400 of FIG. 4, except Video Display 407 is replaced by Head Mounted Display 501. In addition, Head Mounted Display Attitude Sensors 502 are coupled to Computer 405. Head Mounted Display Attitude Sensors 502 measure the attitude of Head Mounted Display 501. This information is used by Computer 405 to produce an additional three dimensional transformation of the data from Digital Database 107 to account for the attitude of the remote pilots Head Mounted Display 501. This does not require any additional data from the remote aircraft. Of course, alternative embodiments could include both a video display and a head mounted display.

FIG. 6 is a block diagram of a simulated remote aircraft used for training remote pilots according to one embodiment of the invention. FIG. 6 shows Remote Aircraft Simulator 600 including Computer 605 coupled to Aerodynamic Model Processor 601, Instructor Control Panel 602, Keyboard 603, Simulation Port 604, Graphics System 606, Storage Device 608, and Simulation Network Interface 609. Remote Aircraft Simulator 600 communicates with Remote Pilot Station 400 or 500 through Simulation Port 604. Aerodynamic Model Processor 601 executes a mathematical model that simulates the behavior of a remote aircraft. An instructor uses Instructor Control Panel 602 and Keyboard 603 to select various training scenarios. Graphics System 606 and Video Display 607 are used to observe the operation of the system. Storage Device 608 is used to record the training session for later evaluation of the session. In addition to proficiency training, the Remote Aircraft Simulator can also be used to practice a proposed mission. The data communicated to the remote pilot station can include training and evaluation data for processing and/or display. This training and evaluation data can include any relevant information, such as flight path accuracy, etc.

Simulation Network Interface 609 permits participation in a battlefield simulation system such as SIMNET, mixing aircraft, tanks, and ground troops for training in the coordination of mixed forces. Thus, the system is designed to allow for the communication of this battlefield simulation information between the remote aircraft simulator and the remote pilot station. This allows the remote pilot station to display one or more other simulated entities (e.g., tanks, ground troops, other aircraft, etc.) described by the battlefield simulation information.

The Database

The Digital Database 107 can be comprised of any type of data from which a three dimensional image can be gener-

ated. For example, the U.S. Geological Survey (USGS) makes available various databases, two of which are of particular interest. The first is the Digital Elevation Model data which consist of an array of regularly spaced terrain elevations.

The other USGS database is the Digital Line Graph data which includes: political and administrative boundaries; hydrography consisting of all flowing water, standing water, and wetlands; major transportation systems consisting of roads and trails, railroads, pipelines, transmission lines, and airports; and significant manmade structures. The Digital Line Graph data is two-dimensional. In the present invention features such as water, roads, railroads, and pipelines are represented as polygons with elevations determined from the Digital Elevation Model data. Transmission lines and significant manmade structures are defined as three-dimensional objects made of polygons and are placed according to the elevations determined from the Digital Elevation Model data. The different types of objects are tagged so that the remote pilot can select them to be highlighted by category or by specific object.

Data from additional digital databases can also be incorporated. An example of such a database is from Jeppesen Sanderson whose NavData Services division provides aeronautical charts and makes this information available in digital form.

The procedure for generating the synthesized three-dimensional view from the Digital Database may use any number of techniques, including those disclosed in the 1987 patent to Beckwith et al. (U.S. Pat. No. 4,660,157 REAL TIME VIDEO PERSPECTIVE DIGITAL MAP DISPLAY METHOD), and the 1993 patent to Dawson et al. (U.S. Pat. No. 5,179,638 METHOD AND APPARATUS FOR GENERATING A TEXTURE MAPPED PERSPECTIVE VIEW). One disadvantage of generating the synthesized three-dimensional view from these elevation databases in real time is the amount of storage space they require. To avoid this large amount of data storage, one embodiment of Digital Database 107 is composed of terrain data that represents the real terrain using polygons. This database may be generated using any number of techniques. For example, this database may be generated by transforming one or more elevation databases into a polygon database using the technique taught in "Pilot Aid Using a Synthetic Environment", Ser. No. 08/274,394 filed Jul. 11, 1994. Another method for transforming one or more elevation databases into a polygon database is taught in "Digital Map Generator and Display System", Ser. No. 08/543,590, filed Oct. 16, 1995. An example of a three dimensional projected image created from this database is shown in FIG. 7.

While the invention has been described in terms of several embodiments, those skilled in the art will recognize that the invention is not limited to the embodiments described. The method and apparatus of the invention can be practiced with modification and alteration within the spirit and scope of the appended claims. The description is thus to be regarded as illustrative instead of limiting on the invention.

What is claimed is:

1. A system comprising:

- a remotely piloted aircraft including,
 - a position determining system to locate said remotely piloted aircraft's position in three dimensions; and
 - an orientation determining system for determining said remotely piloted aircraft's orientation in three dimensional space;
- a communications system for communicating flight data between a computer and said remotely piloted aircraft,

11

said flight data including said remotely piloted aircraft's position and orientation, said flight data also including flight control information for controlling said remotely piloted aircraft;

a digital database comprising terrain data;

said computer to access said terrain data according to said remotely piloted aircraft's position and to transform said terrain data to provide three dimensional projected image data according to said remotely piloted aircraft's orientation;

a display for displaying said three dimensional projected image data; and

a set of one or more remote flight controls coupled to said computer for inputting said flight control information, wherein said computer is also for determining a delay time for communicating said flight data between said computer and said remotely piloted aircraft, and wherein said computer adjusts the sensitivity of said set of one or more remote flight controls based on said delay time.

2. The system of claim 1, wherein:

said remotely piloted aircraft includes a device for capturing image data; and

said system operates in at least a first mode in which said image data is not transmitted from said remotely piloted aircraft to said computer at a sufficient data rate to allow for real time piloting of the remotely piloted aircraft.

3. The system of claim 1, wherein the flight data communicated between said remotely piloted aircraft and said computer is secured.

4. The system of claim 1, wherein said remotely piloted aircraft further comprises a set of one or more video cameras.

5. The system of claim 4, wherein said communications system is also for communicating video data representing images captured by said set of one or more video cameras, said video data for displaying said images.

6. The system of claim 5, wherein said video data is transmitted on a different communication link than said flight data.

7. The system of claim 4, wherein at least one camera in said set of one or more video cameras is an infrared camera.

8. The system of claim 1, wherein said display is a head mounted display.

9. The system of claim 1, wherein said set of one or more remote flight controls is responsive to manual manipulations.

10. The system of claim 1, wherein said set of one or more remote flight controls allows for inputting absolute pitch and roll angles instead of pitch and roll rates.

11. The system of claim 1, wherein said computer is also used for correcting adverse yaw without requiring input from said set of one or more remote flight controls.

12

12. The system of claim 1, wherein:

said remotely piloted aircraft includes a device for capturing image data; and said system operates in at least a first mode in which said image data is not transmitted from said remotely piloted craft to said computer but stored in said remotely piloted aircraft.

13. A station for flying a remotely piloted aircraft that is real or simulated comprising:

a database comprising terrain data;

a set of remote flight controls for inputting flight control information;

a computer having a communications unit configured to receive status information identifying said remotely piloted aircraft's position and orientation in three dimensional space, said computer configured to access said terrain data according to said status information and configured to transform said terrain data to provide three dimensional projected image data representing said remotely piloted aircraft's environment, said computer coupled to said set of remote flight controls and said communications unit for transmitting said flight control information to control said remotely piloted aircraft, said computer also to determine a delay time for communicating said flight control information between said computer and said remotely piloted aircraft, and said computer to adjust the sensitivity of said set of remote flight controls based on said delay time; and

a display configured to display said three dimensional projected image data.

14. The station of claim 13, wherein said communications unit is also configured to receive video data representing images captured by a set of video cameras on said remotely piloted aircraft, said video data for displaying said images.

15. The station of claim 14, wherein said video data is transmitted on a different communication link than said flight control information and said status information.

16. The station of claim 13, wherein said display is a head mounted display.

17. The station of claim 13, wherein said set of remote flight controls is responsive to manual manipulations.

18. The station of claim 13, wherein said set of remote flight controls are configured to allow inputting absolute pitch and roll angles instead of pitch and roll rates.

19. The station of claim 13, wherein said computer is also configured to correct adverse yaw without requiring input from said set of remote flight controls.

20. The station of claim 13, wherein said communications unit includes at least one of a communications transceiver and a simulation port.

* * * * *

United States Patent [19]

[11] Patent Number: 5,904,724

Margolin

[45] Date of Patent: May 18, 1999

[54] METHOD AND APPARATUS FOR REMOTELY PILOTING AN AIRCRAFT
 [76] Inventor: Jed Margolin, 3570 Pleasant Echo, San Jose, Calif. 95148

5,406,286 4/1995 Tran et al. 342/13
 5,446,666 8/1995 Bauer 364/434
 5,552,983 9/1996 Thornberg et al. 364/424.027
 5,581,250 12/1996 Khviliviky 340/961

OTHER PUBLICATIONS

Lyons, J.W., "Some Navigational Concepts for Remotely Piloted Vehicles", AGARD Conference Proceed, n 176, Med. Accur. Low Cost Navig. at Avion, Panel Tec. Meeting, 5-1-5-15, Sep. 1975.

"US GeoData Digital Line Graphs", U.S. Dept. of the Interior, U.S. Geol. Surv. Earth Sci. Info Ctr. (Factsheet) Jun. 1993.

"US GeoData Digital Elevation Models", U.S. Dept. of the Interior, U.S. Geol. Surv. Earth Sci. Info Ctr. (Factsheet) Jun. 1993.

Shifrin, Carole A., "Gripen Likely to Fly Again Soon," *Aviation Week & Space Technology*, Aug. 23, 1993, pp. 72-73.

Primary Examiner—Tan Q. Nguyen
 Attorney, Agent, or Firm—Blakely, Sokoloff, Taylor and Zafman LLP

[21] Appl. No.: 08/587,731
 [22] Filed: Jan. 19, 1996
 [51] Int. Cl.⁶ G06F 165/00; H04N 7/18
 [52] U.S. Cl. 701/120; 701/2; 701/24; 244/189; 244/190; 348/114
 [58] Field of Search 364/423.099, 424.012, 364/424.013, 424.021, 424.022, 449.2, 449.7, 460, 439, 424.028; 340/825.69, 825.72, 967, 989, 991, 992, 993; 244/189, 190, 181, 17.13, 3.11, 3.15; 348/42, 51, 113, 114, 117, 123, 143; 382/154; 395/118, 119, 125

[56] References Cited

U.S. PATENT DOCUMENTS

3,742,495	6/1973	Diamantides	342/64
3,795,909	3/1974	Vehrs, Jr.	343/7
4,218,702	8/1980	Brocard et al.	348/144
4,405,943	9/1983	Kanaly	358/133
4,467,429	8/1984	Kendig	343/433
4,660,157	4/1987	Beckwith et al.	345/421
4,739,327	4/1988	Konig et al.	342/26
4,760,396	7/1988	Barney et al.	342/65
4,835,532	5/1989	Fant	382/284
4,855,822	8/1989	Naredra et al.	364/423.099
4,964,598	10/1990	Berejik et al.	244/190
5,015,187	5/1991	Lord	364/462
5,072,396	12/1991	Fitzpatrick et al.	364/450
5,086,396	2/1992	Waruszewski, Jr.	364/454
5,155,683	10/1992	Rahim	364/424.029
5,179,638	1/1993	Dawson et al.	395/125
5,240,207	8/1993	Eiband et al.	364/423.099
5,257,347	10/1993	Busbridge et al.	395/129
5,266,799	11/1993	Steinitz et al.	324/330
5,272,639	12/1993	McGuffin	364/449
5,335,181	8/1994	McGuffin	364/443
5,381,338	1/1995	Wysocki et al.	348/116

[57] ABSTRACT

A method and apparatus that allows a remote aircraft to be controlled by a remotely located pilot who is presented with a synthesized three-dimensional projected view representing the environment around the remote aircraft. According to one aspect of the invention, a remote aircraft transmits its three-dimensional position and orientation to a remote pilot station. The remote pilot station applies this information to a digital database containing a three dimensional description of the environment around the remote aircraft to present the remote pilot with a three dimensional projected view of this environment. The remote pilot reacts to this view and interacts with the pilot controls, whose signals are transmitted back to the remote aircraft. In addition, the system compensates for the communications delay between the remote aircraft and the remote pilot station by controlling the sensitivity of the pilot controls.

20 Claims, 7 Drawing Sheets

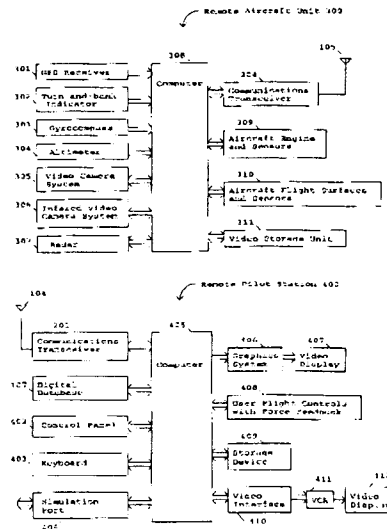

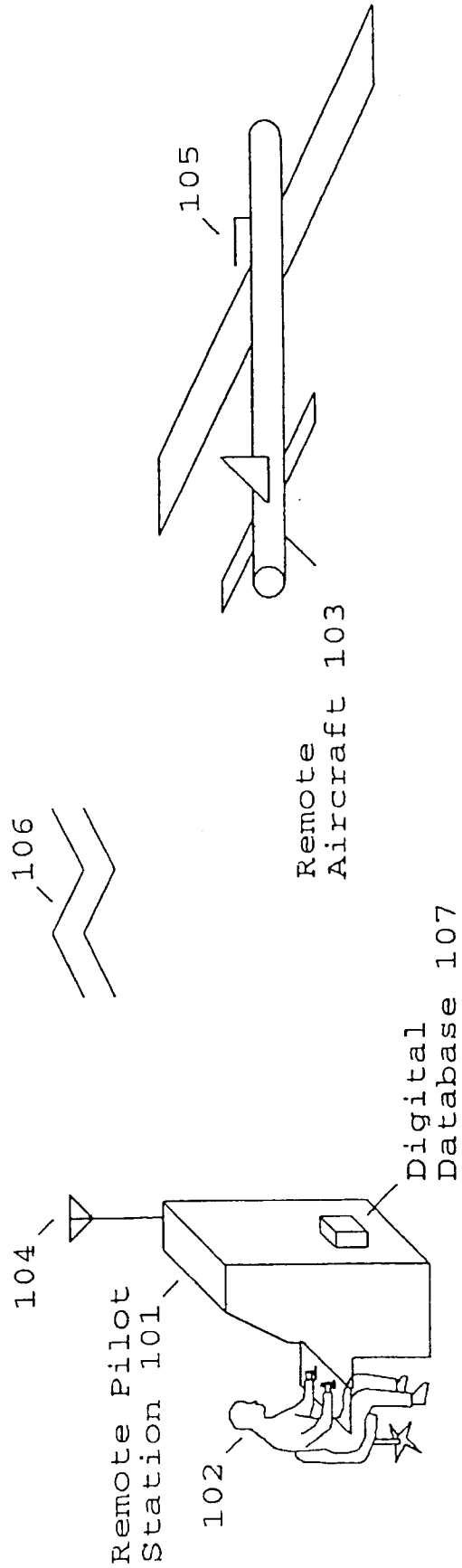

Fig. 1

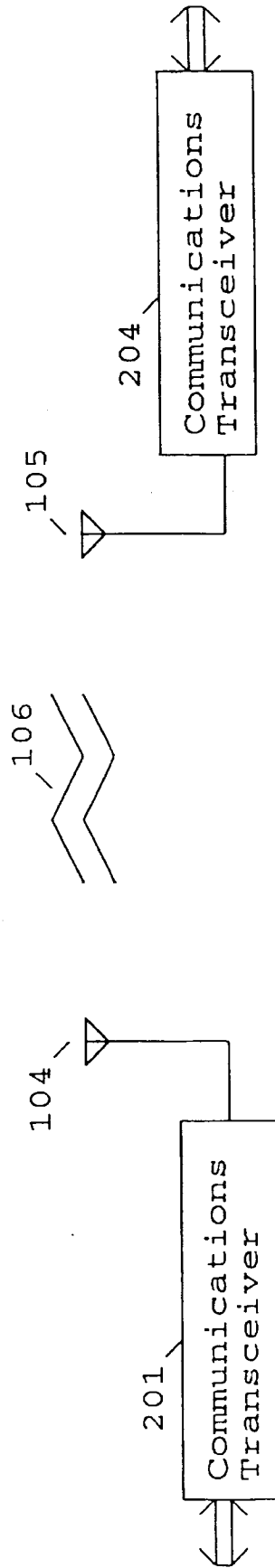

Fig. 2

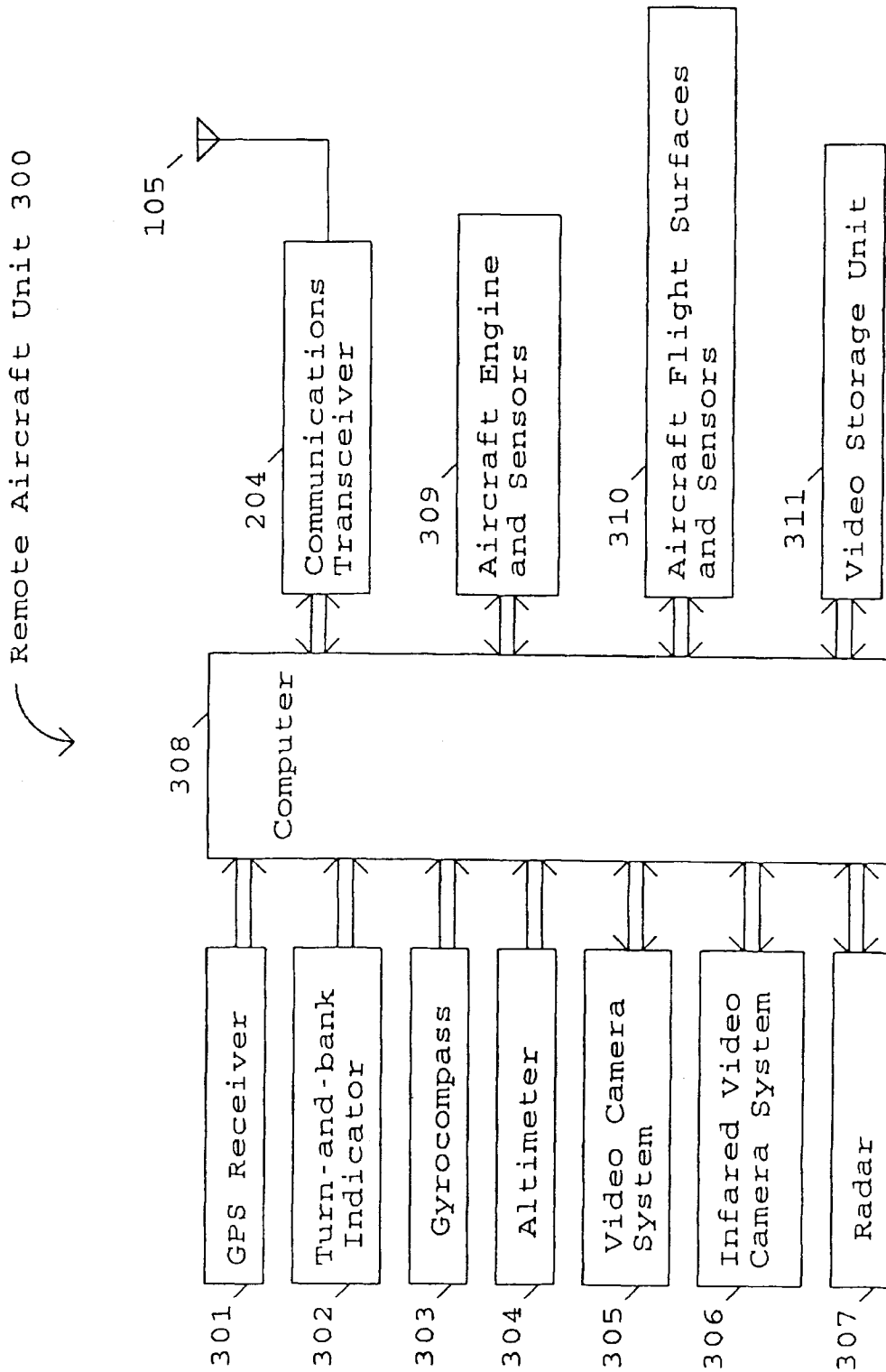

Fig. 3

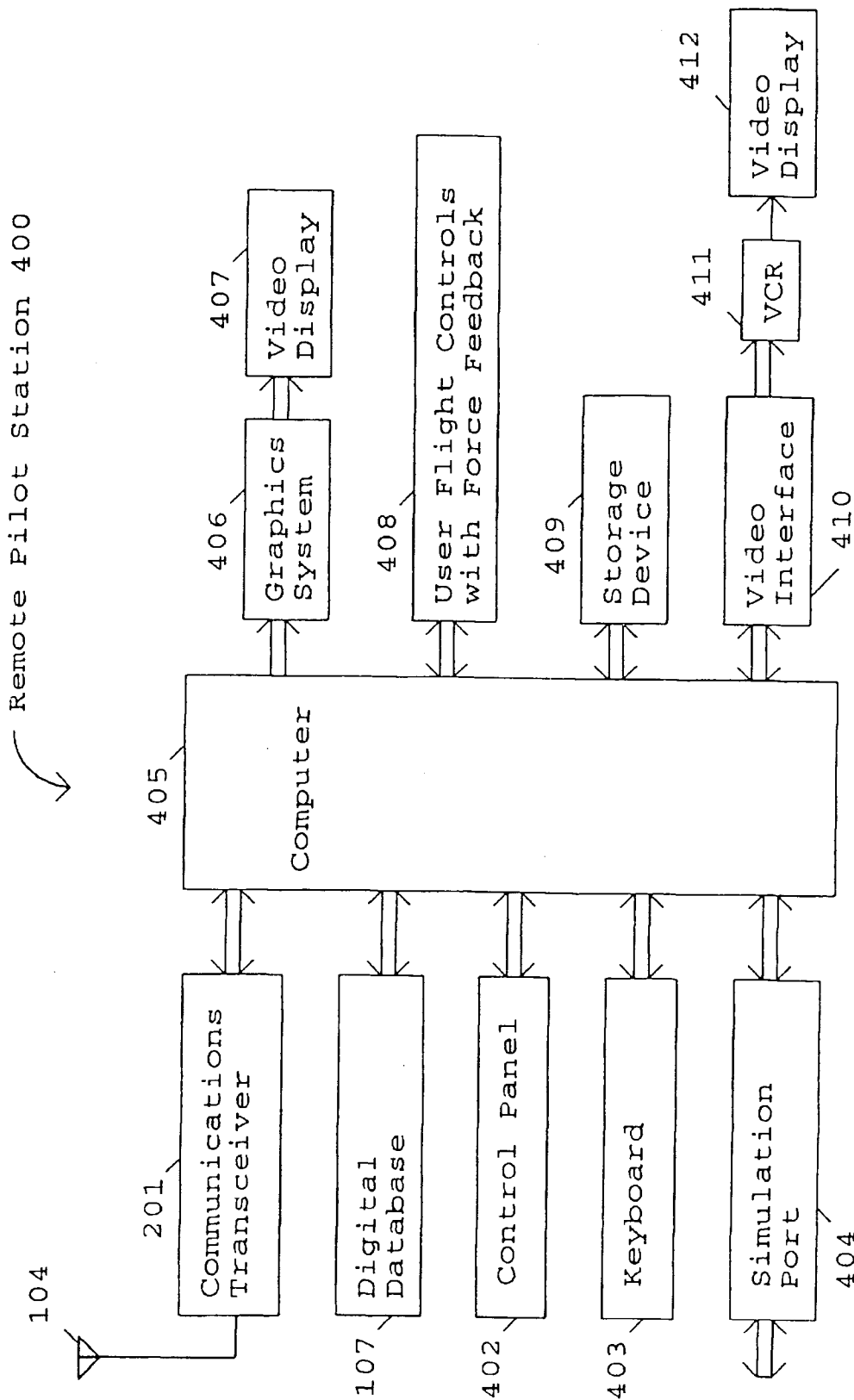

Fig. 4

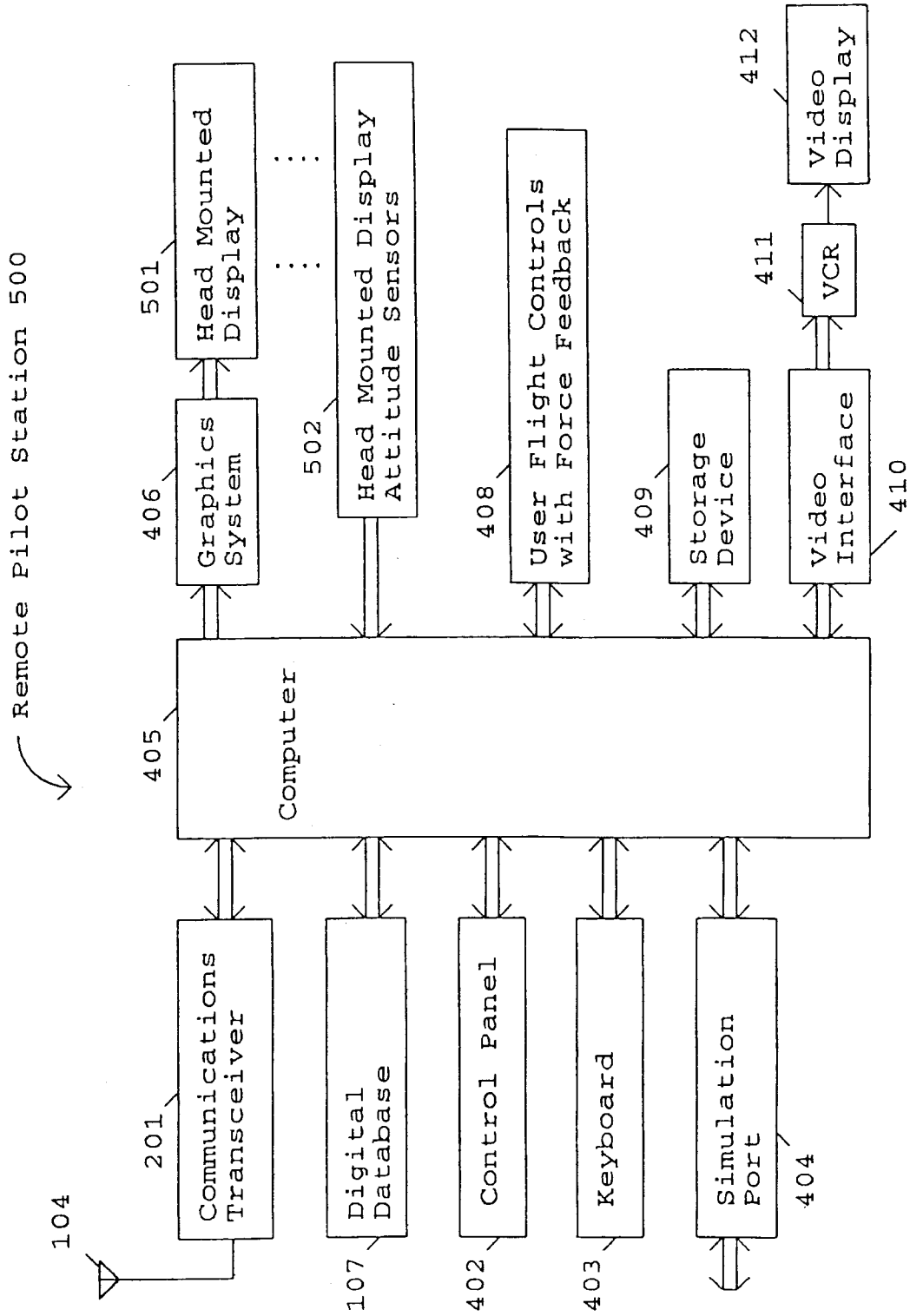

Fig. 5

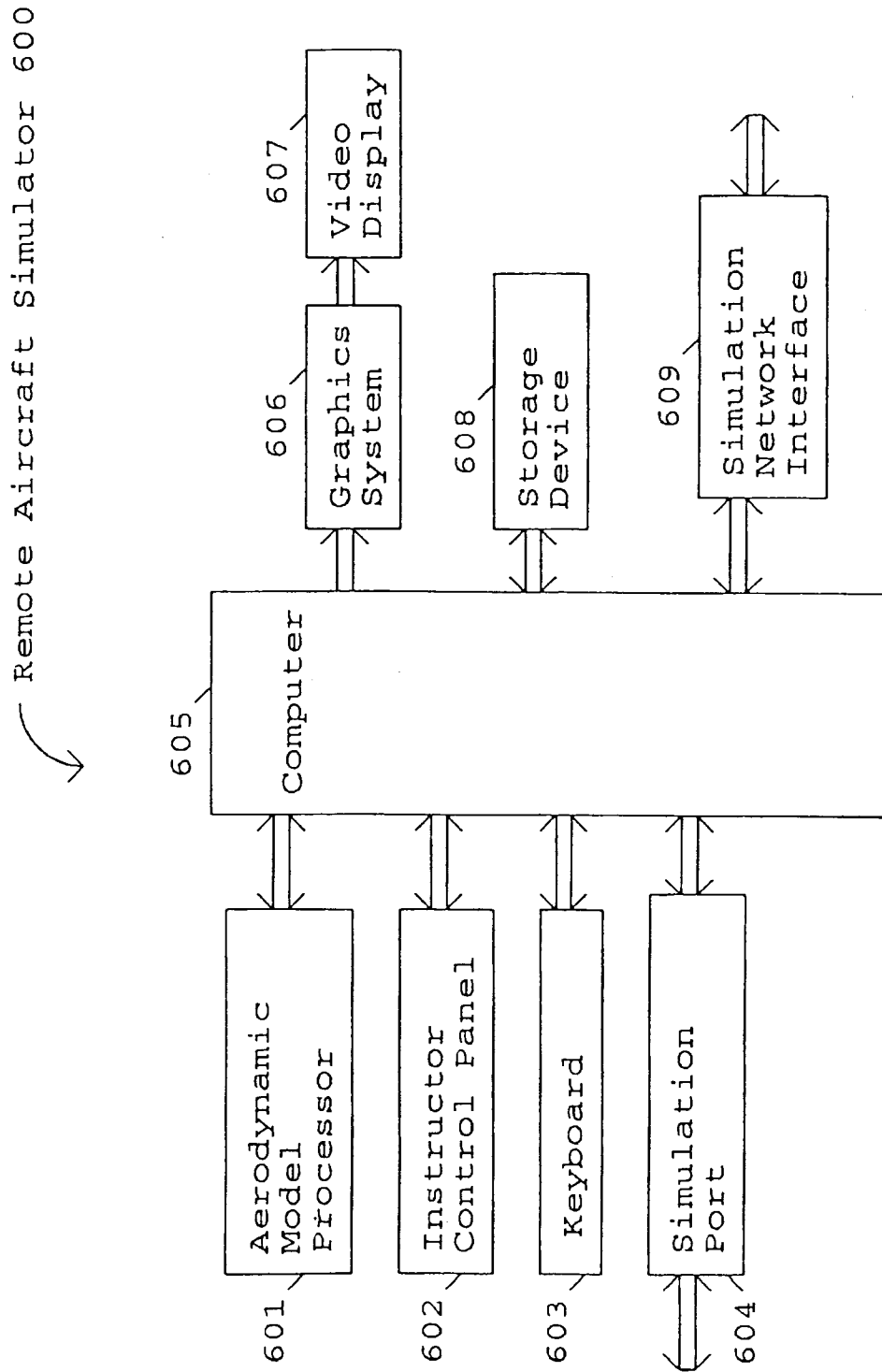

Fig. 6

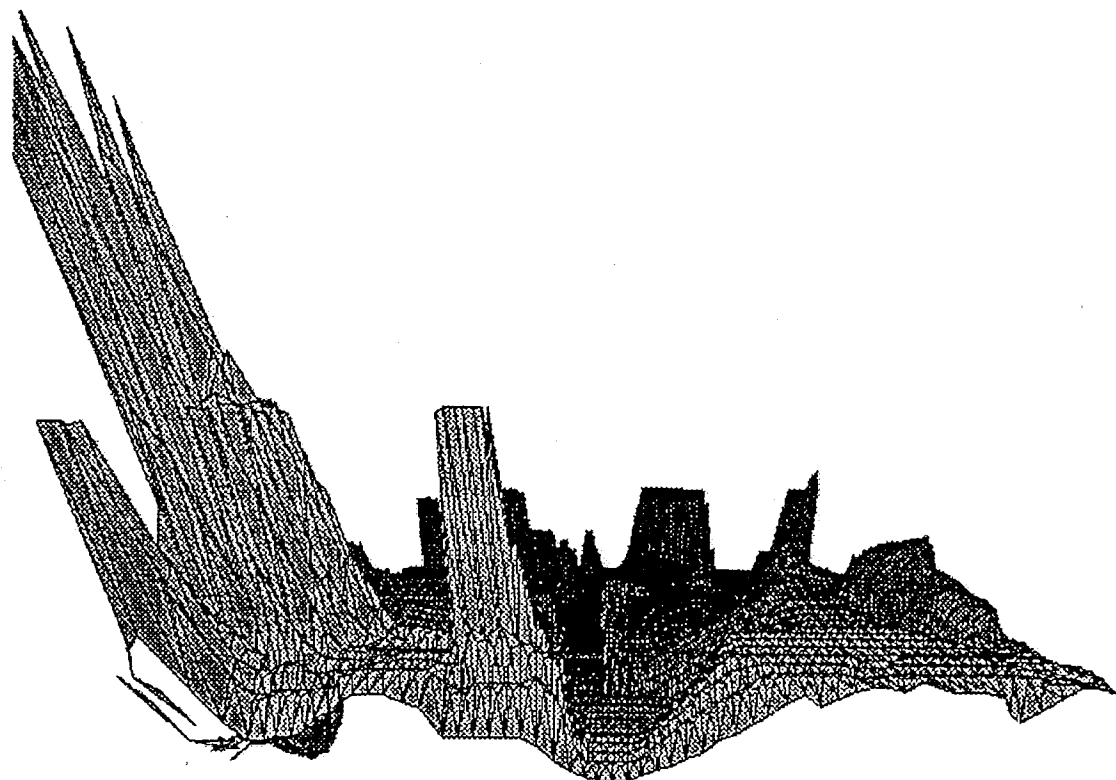

Figure 7

METHOD AND APPARATUS FOR REMOTELY PILOTING AN AIRCRAFT

BACKGROUND OF THE INVENTION—CROSS REFERENCES TO RELATED APPLICATIONS

"Pilot Aid Using a Synthetic Environment", Ser. No. 08/274,394 filed Jul. 11, 1994. "Digital Map Generator and Display System", Ser. No. 08/543,590, filed Oct. 16, 1995.

1. Field of Invention

This invention relates to the field of remotely piloted vehicles (RPVs) and unmanned aerial vehicles (UAVs).

2. Discussion of Prior Art

RPVs can be used for any number of purposes. For example, there is a large organization that promotes the use of remote controlled planes. Certain RPVs are controlled by viewing the plane with the naked eye and using a hand held controller to control its flight. Other RPVs are controlled by a remote pilot using simple joysticks while watching the video produced by a camera in the remote aircraft. This camera is also used to produce the reconnaissance video. There are tradeoffs involving the resolution of the video, the rate at which the video is updated, and the bandwidth needed to transmit it. The wider the bandwidth the more difficult it is to secure the signal. The freedom to balance these tradeoffs is limited because this video is also used to pilot the aircraft and must therefore be updated frequently.

Certain UAVs are preprogrammed to follow a predetermined course and lack the flexibility to deal with unexpected situations.

The 1983 patent to Kanaly (U.S. Pat. No. 4,405,943) shows a control and communications system for a remotely piloted vehicle where an oculometer determines where the remote operator is looking and signals the remote vehicle to send the high resolution imagery corresponding to the area around where the remote operator is looking and low resolution imagery corresponding to the remote operator's peripheral vision. The objective is to minimize the bandwidth of the information transmitted to the remote operator.

SUMMARY

A method and apparatus is described that allows a remote aircraft to be controlled by a remotely located pilot who is presented with a synthesized three-dimensional projected view representing the environment around the remote aircraft. According to one aspect of the invention, a system is used that includes an aircraft and a remote pilot station.

The aircraft uses a communications link to send its location, attitude, and other operating conditions to the remote pilot station. The remote pilot station receives the data and uses a database describing the terrain and manmade structures in the remote aircrafts environment to produce a 3D view of the remote aircraft environment and present it to the remote human pilot.

The remote pilot responds to the information and manipulates the remote flight controls, whose positions and forces are transmitted to the remote aircraft. Since the amount of data is small, it can be readily secured through encryption and spread spectrum techniques.

Also, because the video reconnaissance cameras are no longer needed to remotely pilot the aircraft there is great flexibility in their use. To minimize bandwidth and reduce the possibility of being detected, the video data can be sent at a slow update rate. The data can also be stored on the remote aircraft for later transmission. Alternatively, low resolution pictures can be sent in real-time, while the cor-

responding high resolution pictures can be at a later time. The reconnaissance video can even be transmitted through a different communications link than the control data. There may also be more than one reconnaissance camera.

The delay in the control link must be minimized in order that the remote aircraft can be properly flown. The system can measure the link delay and make this information available to the pilot. This delay link measurement can also be used to modify the control software through which the remote pilot flies the remote aircraft. This is to prevent pilot-induced-oscillation.

The computers in the system allow for several modes of operation. For example, the remote aircraft can be instructed to fly to given coordinates without further input from the remote pilot. It also makes it possible to provide computer assistance to the remote pilot. In this mode, the remote flight control controls absolute pitch and roll angles instead pitch and roll rates which is the normal mode for aircraft. In addition, adverse yaw can be automatically corrected so that the resulting control laws make the remote aircraft extremely easy to fly. Because this comes at the expense of being able to put the remote aircraft into unusual attitudes, for complete control of the remote aircraft a standard control mode is provided to give the remote pilot the same type of control that is used to fly a manned aircraft. Since the remote aircraft is unmanned, the remote pilot can subject the remote aircraft to high-G maneuvers that would not be safe for a pilot present in the aircraft.

To facilitate training, a simulated remote aircraft is provided that allows an instructor to set up the training mission and parameters. This is especially useful in giving remote pilots experience flying with different control link delays. In this simulated mode, the system can be further linked to a battlefield simulator such as SIMNET.

In the first embodiment, the remote pilot is provided with a standard video display. Additional display channels can be provided to give the remote pilot a greater field of view. There can even be a display channel to give a rearward facing view.

A second embodiment uses a head mounted display for the remote pilot instead of a standard display. This permits the remote station to be made more compact so that it can be used in a wider variety of installations. An example would be in a manned aircraft flying several hundred miles away.

BRIEF DESCRIPTION OF THE DRAWINGS

The invention may best be understood by referring to the following description and accompanying drawings which illustrate the invention. In the drawings:

FIG. 1 is a general illustration showing a remote pilot at a remote pilot station operating a remote aircraft according to one embodiment of the invention.

FIG. 2 is a block diagram showing the communications link between a remote pilot station and a remote aircraft according to one embodiment of the invention.

FIG. 3 is a block diagram of a remote aircraft according to one embodiment of the invention.

FIG. 4 is a block diagram of a remote pilot station according to one embodiment of the invention.

FIG. 5 is a block diagram of a remote pilot station according to another embodiment of the invention.

FIG. 6 is a block diagram of a remote aircraft simulator used for training remote pilots according to one embodiment of the invention.

FIG. 7 is an example of a three dimensional projected image presented to a remote pilot by a remote pilot station according to one embodiment of the invention.

DETAILED DESCRIPTION

In the following description, numerous specific details are set forth to provide a thorough understanding of the invention. However, it is understood that the invention may be practiced without these specific details. In other instances, well-known circuits, structures and techniques have not been shown in detail in order not to obscure the invention.

A method and apparatus is described that allows a remote aircraft to be controlled by a remotely located pilot who is presented with a synthesized three-dimensional projected view representing the environment around the remote aircraft. Since the video from a reconnaissance camera located on the remote aircraft is not used to pilot the remote aircraft, the amount of data transmitted between the remote aircraft and the remote pilot is small. This provides greater flexibility in how the remote aircraft is used and allows the transmitted data to be made more secure. The remote aircraft may be of any type, for example a remote control plane or helicopter as used by recreational enthusiast.

FIG. 1 is a general illustration showing a remote pilot at a remote pilot station operating a remote aircraft according to one embodiment of the invention. FIG. 1 shows Remote Pilot 102 interacting with Remote Pilot Station 101 and controlling Remote Aircraft 103. Remote Pilot Station 101 and Remote Aircraft 103 respectively include an Antenna 104 and an Antenna 105 for communicating Information 106.

In one embodiment, Information 106 includes status information concerning the status of Remote Aircraft 103 and flight control information for controlling the flight of Remote Aircraft 103. The status information is generated by Remote Aircraft 103 and includes the three dimensional position and the orientation (also termed attitude, and comprising heading, roll, pitch) of Remote Aircraft 103. The status information may also include information concerning the flight surfaces, the engine, an additional altitude reading, etc. Remote Pilot Station 101 uses this status information to retrieve data from a Digital Database 107 which contains a three-dimensional description of terrain and manmade structures over which Remote Aircraft 103 is flying. Based on the three dimensional data retrieved from Digital Database 107, Remote Pilot Station 101 projects a synthesized three-dimensional projected view of the terrain and manmade structures in the vicinity of Remote Aircraft 103. Based on this view of the terrain and manmade structures, the Remote Pilot Station 101, on its own and/or in response to input from Remote Pilot 102, generates and transmits flight control information to Remote Aircraft 103 which adjusts its flight accordingly.

In one embodiment, the Remote Aircraft 103 is a remote controlled plane or helicopter used for recreational purposes. Since remote controlled planes and helicopters tend to be small in size, the circuitry in such remote aircraft to generate and receive Information 106 is minimized. In such systems, the Remote Pilot Station 101 may be implemented by including additional attachments to an existing portable computer. This allows the user to easily transport the remote aircraft and pilot station to an appropriate location for flight.

FIG. 2 is a block diagram showing a bi-directional communications link between a remote pilot station and a remote aircraft according to one embodiment of the invention. FIG. 2 shows Communications Transceiver 201 coupled to Antenna 104 of Remote Pilot Station 101, as well as Communications Transceiver 204 coupled to Antenna 105 of Remote Aircraft 103. In addition, FIG. 2 shows Information 106 being communicated between Antenna 104 and Antenna 105.

FIG. 3 is a block diagram of a remote aircraft unit used in the remote aircraft according to one embodiment of the invention. FIG. 3 shows Remote Aircraft Unit 300 including Computer 308 coupled to GPS Receiver 301, Turn-and-bank Indicator 302, Gyrocompass 303, Communications Transceiver 204, Aircraft Engine and Sensors 309, and Aircraft Flight Surfaces and Sensors 310. GPS Receiver 301 receives signals from the satellites that make up the global positioning system (GPS) and calculates the aircraft's position in three dimensions. Turn-and-bank Indicator 302 and Gyrocompass 303 provide the aircraft's orientation which comprises heading, roll, and pitch. This data is sent to Computer 308 for transformation into the previously described status information. Computer 308 transmits this status information to Communications Transceiver 204 which produces a radio signal and supplies it to Antenna 105.

The Aircraft Engine and Sensors 309 are coupled to control the aircraft's engine, while the Aircraft Flight Surfaces and Sensors 310 are coupled to control the aircraft's flight surfaces. The flight control information is received from the remote pilot station by Computer 308 through Antenna 105 and Communications Transceiver 204. This flight control information is processed by Computer 308 into the necessary signals for transmission to Aircraft Engine and Sensors 309 and Aircraft Flight Surfaces and Sensors 310 to control the aircraft's engine and flight surfaces, respectively. The operation of the aircraft's flight control surfaces will be later described with reference to FIG. 4.

In order to protect against ECM, the communications link between the Remote Pilot Station 101 and the Remote Aircraft 103 may be secured. While any number of different techniques may be used to secure this link, in one embodiment Computer 308 is implemented to encrypt/decrypt the data transmitted and Communications Transceiver 204 is implemented to use spread spectrum techniques.

Computer 308 may optionally be coupled to Altimeter 304, Video Camera System 305, Infrared Video Camera System 306, Radar 307, and/or Video Storage Unit 311. Altimeter 304 provides an output of the aircraft's altitude as a safety check in the event GPS Receiver 301 malfunctions. Thus, this additional altitude reading may also be transmitted to Remote Pilot Station 101 as part of the status information.

Video Camera System 305 is controlled by Computer 308 which determines where the camera is pointing as well as focusing and the zoom factor. The video produced by the camera is not used by the remote pilot for flying the remote aircraft, so there is more flexibility in using the video. As a result, any number of techniques can be used for receiving the images captured by Video Camera System 305. As examples:

1. High resolution, high update images may be sent back in real-time through the Communications Link, when the high bandwidth needed can be tolerated.
2. High resolution, low update images may be sent back in real-time through the Communications Link to reduce the bandwidth.
3. The video may be recorded in Video Storage Unit 311 for later transmission.
4. The video may be transmitted through a separate communications link.
5. There may be multiple video cameras.

Infrared Video Camera System 306 is similar to Video Camera System 305 and has the same operating modes.

Radar 307 in Remote Aircraft 103 may be passive or active. It may scan a particular pattern or it may track a

selected object. Radar 307 may consist of several Radar units. The information from Radar 307 is processed by Computer 308 so that only the desired information is transmitted over the communication link to the Remote Pilot Station 101 for display.

FIG. 4 is a block diagram of a remote pilot station according to one embodiment of the invention. FIG. 4 shows a Remote Pilot Station 400 including a Computer 405 coupled to Communications Transceiver 201, Digital Database 107, Graphics System 406, User Flight Controls with Force Feedback 408, and a Storage Device 409. The Storage Device 409 represents one or more mechanisms for storing data. For example, the Storage Device 409 may include read only memory (TROM), random access memory (RAM), magnetic disk storage mediums, optical storage mediums, flash memory devices, and/or other machine-readable mediums. Of course, Digital Database 107 may be stored in one or more machine-readable mediums and/or in Storage Device 409.

As previously described, Antenna 104 receives the radio signals transmitted by Remote Aircraft 103 representing the status information of Remote Aircraft 103. These radio signals are transformed by Communications Transceiver 201 and sent to Computer 405. Communications Transceiver 201 is set to the same mode as Communications Transceiver 204, so that if, for example, spread spectrum techniques are used, the signal will be transparently received. Computer 405 recovers the data (de-encrypting, if required) so that the data communications from Computer 308 in the Remote Aircraft to Computer 405 in the Remote Pilot Station is transparent. Thus, the bi-directional communications link comprises the combination of Communications Transceiver 201, Antenna 104, Antenna 105, and Communications Transceiver 204.

As previously described, the status information received by Computer 405 includes the three dimensional position and the orientation of Remote Aircraft 103. The status information may also include information concerning the flight surfaces, flight sensors, the engine, an additional altitude reading, etc. Computer 405 uses this status information to retrieve data from Digital Database 107 which contains a three-dimensional description of terrain and man-made structures over which Remote Aircraft 103 is flying. The composition and creation of the Digital Database 107 is further described later. Based on the three dimensional data retrieved from Digital Database 107, Computer 405 performs the mathematical operations to transform and project the three dimensional data to generate video data representing a synthesized three-dimensional projected view of the terrain (and, if desired, manmade structures) in the vicinity or environment of Remote Aircraft 103. This video data is transmitted to Graphics System 406, which displays the synthesized three-dimensional projected view on Video Display 407.

Since the image is generated from the digital database, virtually any image of the environment of the Remote Aircraft 103 can be generated. As examples, the pilot may select the environment to be: 1) a simulated image of what would be seen out of the cockpit of a manned aircraft on a similar flight path; 2) a simulated image of what would be seen when looking in any direction (e.g., backwards, out a side window, etc.); 3) a simulated image of what would be seen if a camera were tailing the remotely piloted aircraft; etc. In addition, the simulated image may be set to any magnification. Thus, the phrase environment of Remote Aircraft 103 is intended to include any image generated with reference to the remote aircraft's position.

The User Flight controls with Force Feedback 408 are used by the remote pilot to input flight path information. The User Flight Controls may be of any number of different types, some of which are further described later herein. The status information received by Computer 405 also includes information received from Aircraft Flight Surfaces and Sensors 310. This information is used to actuate force feedback circuitry in User Flight Controls With Force Feedback 408. Remote Pilot 102 observes the synthesized three-dimensional environment displayed on Video Display 407, feels the forces on User Flight Controls With Force Feedback 408 and moves the controls accordingly. This flight control information is sent through the communications link, to Computer 308, and is used to control the aircraft flight surfaces in Aircraft Flight Surfaces and Sensors 310. Remote Pilot 102 also receives data from Aircraft Engine and Sensors 309 through the communications link and is able to send data back to control the engine.

Flight Control

To illustrate the operation of the remote aircraft, a fixed-wing airplane will be described as an example. However, the basic principles apply to other types of aircraft as well. The basic control surfaces of an airplane consist of the ailerons, the horizontal elevators, and the rudder. The ailerons are moved differentially (one up, one down) to rotate the airplane around its roll axis; the horizontal elevators cause the airplane to rotate around its pitch axis; and the rudder causes the airplane to rotate around its yaw axis.

When the ailerons are used to modify the lift characteristics of the wings, one wing creates more lift while the other wing creates less lift. This also changes the drag characteristics of the wings and results in a yaw force that is opposite to the yaw force that results from the tail section causing the airplane to weather-cock into the relative wind. It is this yaw force caused by the airplane weather-cocking into the relative wind that causes a banked airplane to turn. The opposite yaw force produced by using the ailerons is called adverse yaw; the rudder control is used to counteract this force to produce a coordinated turn.

The simplest type of flight control consists of a joystick and a set of rudder pedals. The controls are directly connected to the flight control surfaces. With a joystick, moving the stick left and right moves the ailerons, while moving the stick forward and backward moves the horizontal elevators. The rudder is controlled by two foot pedals, one for each foot, that are mounted on a common shaft and hinged in the middle like a seesaw. Pressing one foot pedal forward causes the other foot pedal to move backward and causes the rudder to also move in one direction. Pressing the other foot pedal causes it to move forward and the opposite pedal to move backward and causes the rudder to move in the opposite direction.

An alternative to the joystick is the control yoke which consists of a wheel attached to a shaft that moves in and out of the control housing. Turning the wheel clockwise or counterclockwise moves the ailerons; moving the wheel shaft in and out moves the horizontal elevators. The rudder pedals are the same as those used with a joystick.

In order to aid in a description of remote aircraft operation, it is thought worthwhile to first describe the operation of non-remotely piloted vehicles. Non-remotely piloted vehicles can be operated in one of two ways (also termed as flight control modes); direct control or computer control (also termed as computer mediated).

Direct Control Non-Remotely Piloted Vehicles

When the flight controls are connected directly to the control surfaces the result is a second order system. Using

the joystick as an example, moving the joystick left or right establishes a roll rate. The airplane continues to roll until the joystick is returned to the center position, after which the airplane remains in the bank angle thus established. The foot pedals are used to counteract the adverse yaw as previously described. Moving the joystick forward or backward establishes a pitch rate. The airplane continues to pitch until the joystick is returned to the center position, after which the airplane remains in the pitch angle thus established. Both the roll rate and the pitch rate are subject to the limits of the airplane's design.

Since the joystick is directly connected to the control surfaces, the aerodynamic forces on the control surfaces are transmitted back to the pilot, giving him or her valuable feedback on how the airplane is flying.

The successful operation of the second order system with the pilot in the loop depends on several factors such as the area and placement of the control surfaces, how much the control surfaces move in response to the movement of the pilot controls, and how long the airplane takes to respond to changes of the control surfaces. The total system characteristics also depend on the reaction time of the pilot. If the resulting system is poorly designed it may be unstable, which means it may not be possible for a human pilot to fly it safely. An example of an unstable system is where the pilot desires to perform a gentle roll to the right and so moves the joystick to the right, the airplane's roll rate is faster than the pilot desires so he/she attempts to compensate by moving the joystick to the left, the airplane rolls left at a rate that is faster than the pilot desires so he/she moves the joystick to the right, and so on, with the pilot constantly overcorrecting and with the aircraft's rolling motions constantly getting larger and larger until the aircraft gets into a condition from which it may not be possible to recover, (e.g., spinning into the ground). The type of loss of control described is usually referred to as 'pilot induced oscillation' and although it may be caused by an inexperienced or inattentive pilot, it is more often caused by poor airplane design. Therefore, new airplane designs are extensively tested to make sure they can be safely flown. Examples of airplanes that use direct control of the control surfaces (Direct Control Second Order Systems) are the Cessna 150 and the Piper Cub.

Computer Mediated Non-Remotely Piloted Vehicles

Computer mediated control systems use a computer between the pilot controls and the control surfaces. The pilot controls are read by the computer, the data are modified in a particular way, and the computer sends control signals to the control surfaces. The computer may also sense the forces on the control surface and use it to control force feedback to the pilot controls. This type of computer mediated control may be used to fly an airplane that would otherwise be unstable, such as the F16 or the F117. Aircraft such as the F16 and F117 are also second order systems because the position of the pilot's joystick represents rate of rotation.

There are risks inherent in a computer mediated system. Although the program can be simulated extensively before using it in an actual airplane, the computer program may be quite large and therefore difficult to simulate under all possible conditions. An example of this is the Swedish JAS 39 Gripen Fighter. Despite extensive simulation of the flight control system, during a test flight a Gripen crashed due to "... the flight control system's high amplification of stick commands combined with the pilot's" large, rapid stick movements". The pilot had entered a low-speed high-banked turn at a 280 meter altitude with lit afterburners and

was leaving the turn when his actions led to 'pilot-induced oscillation'. (Aviation Week & Space Technology, Aug. 23, 1993, pages 72-73).

Having described techniques for operating non-remotely piloted vehicles, the Fight Control Modes for RPVs will be described.

Second Order RPV Flight Control Mode

A second order control system for an RPV is inherently computer mediated because the remote pilot must interact through two computers: the computer in the remote aircraft and the computer in the remote pilot station.

Flying an RPV is further complicated because there are additional time delays in the loop. The computer in the remote aircraft must first determine the aircraft's position and orientation. The additional processing for transmitting a secure signal by encryption and/or spread spectrum techniques may create additional delays. Transmission delay of signals between the remote aircraft and remote pilot station is negligible for a direct path. However, if the signals are relayed through other facilities the delay time may be appreciable, especially if an orbiting satellite is used. There are additional delays in the remote pilot station as the remote aircraft's position and orientation are used to transform the data from the digital database to present the pilot with the synthesized 3D projected view from the remote aircraft. In one embodiment, the RPV system measures the various delays and modifies the control laws used by the computer in the remote pilot aircraft and in the feedback provided by the computer in the remote pilot station to the remote pilot. For example, the computer may adjust the sensitivity of the User Flight Controls 408 according to the delay (e.g., as the delay increases, the computer will decrease the sensitivity of the flight controls). The system also displays the measured delay to the remote pilot.

First Order RPV Flight Control Mode

The stability of the flight control system, and thus the flyability of an RPV, can be improved considerably by using a first order system. In one embodiment of such a first order system the position of the remote pilot's joystick represents an angle relative to the horizon, instead of representing a rate of rotation as in a second order system. The position of the joystick is transmitted to the computer in the remote aircraft which moves the control surfaces as required to place the remote aircraft in the requested orientation. The control system in the remote aircraft is still a second order system but the delays in the communications link and the remote pilot station are no longer a part of the system's loop.

When a joystick is centered, the remote aircraft will fly straight and level. When the joystick is to the right of center the remote aircraft will be in a right banked turn. When the joystick is to the left of center the remote aircraft will be in a left banked turn. When the joystick is backward from center the remote aircraft will be in a pitch up orientation. When the joystick is forward of center the remote aircraft will be in a pitch down orientation.

The amount of bank and pitch permitted depends on the design of the remote aircraft. A high performance remote aircraft will be capable of a greater amount of pitch and bank than will a low performance remote aircraft.

Referring again to FIG. 4, Computer 405 may optionally be coupled to Control Panel 402, Keyboard 403, Simulation Port 404, Video Interface 410, VCR 411, and/or Video Display 412. In one embodiment, Control Panel 402 con-

tains specialized lights, displays, and switches to allow a quicker response to situations than can be provided by Keyboard 403. Control Panel 402 can be arranged to approximate the look and feel of an actual aircraft cockpit. Keyboard 403 allows the remote pilot to select various operating modes. For training purposes, Simulation Port 404 allows the remote pilot station to be connected to a remote aircraft simulator instead of an actual remote aircraft. The remote aircraft simulator will be further described with reference to FIG. 6. Storage Device 409 allows the flight data to be recorded. During playback this previously recorded data is substituted for real-time data from the remote aircraft to replay the mission for analysis. Any video received from any reconnaissance cameras on the Remote Aircraft 103 is converted by Video Interface 410 so that it can be recorded on VCR 411 and displayed on Video Display 412. VCR 411 can also operate in straight-through mode so that the reconnaissance video can be viewed in real time.

FIG. 5 is a block diagram of a remote pilot station according to another embodiment of the invention. FIG. 5 shows Remote Pilot Station 500. Remote Pilot Station 500 is similar to Remote Pilot Station 400 of FIG. 4, except Video Display 407 is replaced by Head Mounted Display 501. In addition, Head Mounted Display Attitude Sensors 502 are coupled to Computer 405. Head Mounted Display Attitude Sensors 502 measure the attitude of Head Mounted Display 501. This information is used by Computer 405 to produce an additional three dimensional transformation of the data from Digital Database 107 to account for the attitude of the remote pilots Head Mounted Display 501. This does not require any additional data from the remote aircraft. Of course, alternative embodiments could include both a video display and a head mounted display.

FIG. 6 is a block diagram of a simulated remote aircraft used for training remote pilots according to one embodiment of the invention. FIG. 6 shows Remote Aircraft Simulator 600 including Computer 605 coupled to Aerodynamic Model Processor 601, Instructor Control Panel 602, Keyboard 603, Simulation Port 604, Graphics System 606, Storage Device 608, and Simulation Network Interface 609. Remote Aircraft Simulator 600 communicates with Remote Pilot Station 400 or 500 through Simulation Port 604. Aerodynamic Model Processor 601 executes a mathematical model that simulates the behavior of a remote aircraft. An instructor uses Instructor Control Panel 602 and Keyboard 603 to select various training scenarios. Graphics System 606 and Video Display 607 are used to observe the operation of the system. Storage Device 608 is used to record the training session for later evaluation of the session. In addition to proficiency training, the Remote Aircraft Simulator can also be used to practice a proposed mission. The data communicated to the remote pilot station can include training and evaluation data for processing and/or display. This training and evaluation data can include any relevant information, such as flight path accuracy, etc.

Simulation Network Interface 609 permits participation in a battlefield simulation system such as SIMNET, mixing aircraft, tanks, and ground troops for training in the coordination of mixed forces. Thus, the system is designed to allow for the communication of this battlefield simulation information between the remote aircraft simulator and the remote pilot station. This allows the remote pilot station to display one or more other simulated entities (e.g., tanks, ground troops, other aircraft, etc.) described by the battlefield simulation information.

The Database

The Digital Database 107 can be comprised of any type of data from which a three dimensional image can be gener-

ated. For example, the U.S. Geological Survey (USGS) makes available various databases, two of which are of particular interest. The first is the Digital Elevation Model data which consist of an array of regularly spaced terrain elevations.

The other USGS database is the Digital Line Graph data which includes: political and administrative boundaries; hydrography consisting of all flowing water, standing water, and wetlands; major transportation systems consisting of roads and trails, railroads, pipelines, transmission lines, and airports; and significant manmade structures. The Digital Line Graph data is two-dimensional. In the present invention features such as water, roads, railroads, and pipelines are represented as polygons with elevations determined from the Digital Elevation Model data. Transmission lines and significant manmade structures are defined as three-dimensional objects made of polygons and are placed according to the elevations determined from the Digital Elevation Model data. The different types of objects are tagged so that the remote pilot can select them to be highlighted by category or by specific object.

Data from additional digital databases can also be incorporated. An example of such a database is from Jeppesen Sanderson whose NavData Services division provides aeronautical charts and makes this information available in digital form.

The procedure for generating the synthesized three-dimensional view from the Digital Database may use any number of techniques, including those disclosed in the 1987 patent to Beckwith et al. (U.S. Pat. No. 4,660,157 REAL TIME VIDEO PERSPECTIVE DIGITAL MAP DISPLAY METHOD), and the 1993 patent to Dawson et al. (U.S. Pat. No. 5,179,638 METHOD AND APPARATUS FOR GENERATING A TEXTURE MAPPED PERSPECTIVE VIEW). One disadvantage of generating the synthesized three-dimensional view from these elevation databases in real time is the amount of storage space they require. To avoid this large amount of data storage, one embodiment of Digital Database 107 is composed of terrain data that represents the real terrain using polygons. This database may be generated using any number of techniques. For example, this database may be generated by transforming one or more elevation databases into a polygon database using the technique taught in "Pilot Aid Using a Synthetic Environment", Ser. No. 08/274,394 filed Jul. 11, 1994. Another method for transforming one or more elevation databases into a polygon database is taught in "Digital Map Generator and Display System", Ser. No. 08/543,590, filed Oct. 16, 1995. An example of a three dimensional projected image created from this database is shown in FIG. 7.

While the invention has been described in terms of several embodiments, those skilled in the art will recognize that the invention is not limited to the embodiments described. The method and apparatus of the invention can be practiced with modification and alteration within the spirit and scope of the appended claims. The description is thus to be regarded as illustrative instead of limiting on the invention.

What is claimed is:

1. A system comprising:

a remotely piloted aircraft including,
 a position determining system to locate said remotely piloted aircraft's position in three dimensions; and
 an orientation determining system for determining said remotely piloted aircraft's orientation in three dimensional space;

a communications system for communicating flight data between a computer and said remotely piloted aircraft,

11

- said flight data including said remotely piloted aircraft's position and orientation, said flight data also including flight control information for controlling said remotely piloted aircraft;
- a digital database comprising terrain data;
- said computer to access said terrain data according to said remotely piloted aircraft's position and to transform said terrain data to provide three dimensional projected image data according to said remotely piloted aircraft's orientation;
- a display for displaying said three dimensional projected image data; and
- a set of one or more remote flight controls coupled to said computer for inputting said flight control information, wherein said computer is also for determining a delay time for communicating said flight data between said computer and said remotely piloted aircraft, and wherein said computer adjusts the sensitivity of said set of one or more remote flight controls based on said delay time.
2. The system of claim 1, wherein:
- said remotely piloted aircraft includes a device for capturing image data; and
- said system operates in at least a first mode in which said image data is not transmitted from said remotely piloted aircraft to said computer at a sufficient data rate to allow for real time piloting of the remotely piloted aircraft.
3. The system of claim 1, wherein the flight data communicated between said remotely piloted aircraft and said computer is secured.
4. The system of claim 1, wherein said remotely piloted aircraft further comprises a set of one or more video cameras.
5. The system of claim 4, wherein said communications system is also for communicating video data representing images captured by said set of one or more video cameras, said video data for displaying said images.
6. The system of claim 5, wherein said video data is transmitted on a different communication link than said flight data.
7. The system of claim 4, wherein at least one camera in said set of one or more video cameras is an infrared camera.
8. The system of claim 1, wherein said display is a head mounted display.
9. The system of claim 1, wherein said set of one or more remote flight controls is responsive to manual manipulations.
10. The system of claim 1, wherein said set of one or more remote flight controls allows for inputting absolute pitch and roll angles instead of pitch and roll rates.
11. The system of claim 1, wherein said computer is also used for correcting adverse yaw without requiring input from said set of one or more remote flight controls.

12

12. The system of claim 1, wherein:
- said remotely piloted aircraft includes a device for capturing image data; and said system operates in at least a first mode in which said image data is not transmitted from said remotely piloted craft to said computer but stored in said remotely piloted aircraft.
13. A station for flying a remotely piloted aircraft that is real or simulated comprising:
- a database comprising terrain data;
- a set of remote flight controls for inputting flight control information;
- a computer having a communications unit configured to receive status information identifying said remotely piloted aircraft's position and orientation in three dimensional space, said computer configured to access said terrain data according to said status information and configured to transform said terrain data to provide three dimensional projected image data representing said remotely piloted aircraft's environment, said computer coupled to said set of remote flight controls and said communications unit for transmitting said flight control information to control said remotely piloted aircraft, said computer also to determine a delay time for communicating said flight control information between said computer and said remotely piloted aircraft, and said computer to adjust the sensitivity of said set of remote flight controls based on said delay time; and
- a display configured to display said three dimensional projected image data.
14. The station of claim 13, wherein said communications unit is also configured to receive video data representing images captured by a set of video cameras on said remotely piloted aircraft, said video data for displaying said images.
15. The station of claim 14, wherein said video data is transmitted on a different communication link than said flight control information and said status information.
16. The station of claim 13, wherein said display is a head mounted display.
17. The station of claim 13, wherein said set of remote flight controls is responsive to manual manipulations.
18. The station of claim 13, wherein said set of remote flight controls are configured to allow inputting absolute pitch and roll angles instead of pitch and roll rates.
19. The station of claim 13, wherein said computer is also configured to correct adverse yaw without requiring input from said set of remote flight controls.
20. The station of claim 13, wherein said communications unit includes at least one of a communications transceiver and a simulation port.

* * * * *

[REDACTED]

From: McNutt, Jan (HQ-MC000)
Sent: Thursday, January 29, 2009 10:41 AM
To: Hammerle, Kurt G. (JSC-AL)
Cc: Fein, Edward K. (JSC-AL); Rotella, Robert F. (HQ-MA000); Borda, Gary G. (HQ-MC000)
Subject: Margolin Patent Infringement Claim

Kurt,

As we discussed, here are the original claim documents



Margolin Claim
20030607.pdf



Margolin Claim
20030617.pdf



SBIR Margolin
Claim.pdf

*Jan S. McNutt
Senior Attorney (Commercial)
Office of the General Counsel
NASA Headquarters*

[REDACTED]

b(6)

02130

Jed Margolin
[REDACTED] r.
[REDACTED] m

[REDACTED]
June 7, 2003

b(6)

Mr. Alan J. Kennedy
Office of the General Counsel
National Aeronautics and Space Administration
[REDACTED]
[REDACTED]

b(6)

Dear Mr. Kennedy,

Mr. Barry Gibbens of your Langley Research Center suggested I contact you. I missed you when I called on Friday so I am sending this fax to provide background.

I believe that NASA may have used one or more of my patents in connection with the X-38 project and may be using one or more of my patents in other projects using Synthetic Vision.

This fax contains a number of Internet links. If you would like an email version of this fax containing active links please send me an email [REDACTED] with your email address.

b(6)

Summary

In Synthetic Vision (NASA's term), the aircraft's position and orientation are used with a terrain database (such as the Digital Elevation Database) to produce a 3D projected view of the terrain over which the aircraft is flying. One of the advantages of this system is that the pilot is able to "see" the terrain regardless of weather conditions or whether it is day or night.

My U.S. Patent that pertains to this use of synthetic vision is: **U.S. Patent 5,566,073 Pilot Aid Using a Synthetic Environment** issued October 15, 1996 to Margolin. (I am the inventor and owner of the patent.) The patent application was filed August 9, 1995, and was a continuation of Application Ser. No. 08/274,394, filed July 11, 1994.

With synthetic vision it is not necessary for the pilot to be in the aircraft. I believe the X-38 project used this method.

My U.S. Patent that pertains to this use of synthetic vision is: **U.S. Patent 5,904,724 Method and Apparatus For Remotely Piloting an Aircraft** issued May 18, 1999 to Margolin. (I am the inventor and owner of the patent.) The patent application was filed January 19, 1996.

02131

X-38 Project

I became aware that NASA was using synthetic vision in the X-38 project in the January 2003 issue of NASA Tech Briefs, page 40, "**Virtual Cockpit Window**" for a Windowless Aerospacecraft. The article is available at: <http://www.nasatech.com/Briefs/Jan03/MSC23096.html>

This led me to Rapid Imaging Software, Inc. and their press release (<http://www.landform.com/pages/PressReleases.htm>) which states:

"On December 13th, 2001, Astronaut Ken Ham successfully flew the X-38 from a remote cockpit using LandForm VisualFlight as his primary situation awareness display in a flight test at Edwards Air Force Base, California. This simulates conditions of a real flight for the windowless spacecraft, which will eventually become NASA's Crew Return Vehicle for the ISS. We believe that this is the first test of a hybrid synthetic vision system which combines nose camera video with a LandForm synthetic vision display. Described by astronauts as 'the best seat in the house', the system will ultimately make space travel safer by providing situation awareness during the landing phase of flight."

The RIS press release provided a link to an article in Aviation Week & Space Technology: http://www.aviationnow.com/avnow/news/channel_space.jsp?view=story&id=news/sx381211.xml

As a result of more searching I have discovered a link to a Johnson Space Center SBIR Phase II award to Rapid Imaging Systems at <http://sbir.gsfc.nasa.gov/SBIR/successes/ss/9-058text.html> .

It includes a particularly relevant paragraph:

The Advanced Flight Visualization Toolkit (VisualFlight™) project is developing a suite of virtual reality immersive telepresence software tools which combine the real-time flight simulation abilities with the data density of a Geographic Information System (GIS). This technology is used for virtual reality training of crews, analysis of flight test data, and as an on-board immersive situation display. It will also find application as a virtual cockpit, and in teleoperation of remotely piloted vehicles.

{The emphasis on teleoperation of remotely piloted vehicles is mine.}

A search of the SBIR archive shows the following entries.

For 2001 Phase I:

Rapid Imaging Software, Inc.

[REDACTED]

b(6)

Integrated Video for Synthetic Vision Systems

For 2001 Phase II:

Rapid Imaging Software, Inc.

[REDACTED]

b(6)

(213)

Carolyn Galceran [REDACTED]
01-2-H6.02-8715 JSC
Integrated Video for Synthetic Vision Systems

b(6)³

My U.S. Patent that pertains to this use of synthetic vision is: **U.S. Patent 5,904,724 Method and Apparatus For Remotely Piloting an Aircraft** issued May 18, 1999 to Margolin. (I am the inventor and owner of the patent.) The patent application was filed January 19, 1996.

The patent can be downloaded from the UPTO Web site (www.uspto.gov) in html (no drawings) or in an odd tif format (with the drawings) that requires a special viewer.

An easier way to view and download the patent is through my Web site, on which I have posted the patent in PDF format. The link is <http://www.jmargolin.com/patents2/rpv.htm>.

While I have no way of knowing exactly what method(s) NASA used in controlling the X-38 (unless you are willing to make a full disclosure) my patent covers techniques as exemplified by claim 1.

1. A system comprising:

a remotely piloted aircraft including,

a position determining system to locate said remotely piloted aircraft's position in three dimensions; and

an orientation determining system for determining said remotely piloted aircraft's orientation in three dimensional space;

a communications system for communicating flight data between a computer and said remotely piloted aircraft, said flight data including said remotely piloted aircraft's position and orientation, said flight data also including flight control information for controlling said remotely piloted aircraft;

a digital database comprising terrain data;

said computer to access said terrain data according to said remotely piloted aircraft's position and to transform said terrain data to provide three dimensional projected image data according to said remotely piloted aircraft's orientation;

a display for displaying said three dimensional projected image data; and

a set of one or more remote flight controls coupled to said computer for inputting said flight control information, wherein said computer is also for determining a delay time for communicating said flight data between said computer and said remotely piloted aircraft, and wherein said computer adjusts the sensitivity of said set of one or more remote flight controls based on said delay time.

Although the X-38 project has been canceled, the methods developed to fly it are too good to waste and should be used in follow-up projects like CRV.

02133

Synthetic Vision

I became aware of NASA's Synthetic Vision program perhaps two years ago from a program on NASA TV. I was unable to follow it up at that time due to health problems and the demands of my other patenting activity.

According to the NASA Aviation Safety Program Web site (http://avsp.larc.nasa.gov/program_svs.html)

Synthetic Vision Systems

TECHNOLOGY WOULD REDUCE AIRLINE FATALITIES
Synthetic Vision would give pilots clear skies all the time

A revolutionary cockpit display system being developed with seed money from NASA would help prevent the world's deadliest aviation accidents.

And I agree.

My U.S. Patent that pertains to this use of synthetic vision is: **U.S. Patent 5,566,073 Pilot Aid Using a Synthetic Environment** issued October 15, 1996 to Margolin. (I am the inventor and owner of the patent.) The patent application was filed August 9, 1995, and was a continuation of Application Ser. No. 08/274,394, filed July 11, 1994.

The patent can be downloaded from the USPTO Web site (www.uspto.gov) in html (no drawings) or in an odd tif format (with the drawings) that requires a special viewer.

The patent can also be downloaded from my Web site in PDF format at:
<http://www.jmargolin.com/patents2/pilot.htm>

As with the X-38 program I have no way of knowing exactly what method(s) NASA used in its Synthetic Vision program (unless you are willing to make a full disclosure). My patent covers techniques as exemplified by claim 1.

1. A pilot aid which uses an aircraft's position and attitude to transform data from a digital data base to present a pilot with a synthesized three dimensional projected view of the world comprising:

a position determining system for locating said aircraft's position in three dimensions;

a digital data base comprising terrain data, said terrain data representing real terrestrial terrain as at least one polygon, said terrain data generated from elevation data of said real terrestrial terrain;

an attitude determining system for determining said aircraft's orientation in three dimensional space;

a computer to access said terrain data according to said aircraft's position and to transform said terrain data to provide three dimensional projected image data according to said aircraft's orientation; and

a display for displaying said three dimensional projected image data.

NASA's Visits to My Web Site

There is good reason to believe that NASA was aware of my work in these areas through visits to my Web site. NASA has been visiting my Web site (www.jmargolin.com) regularly since I started it in December 2000. (I have no objection to NASA's visits; I am flattered that NASA considers my Web site worth visiting.)

A listing of NASA access statistics follows the end of this fax.

I also have regular visits from <http://cap.nipr.mil>, which I understand is a secure gateway to other military networks. I don't know if NASA uses nipr so I have not included it in my listing.

The Web Statistics software provided by my Web Hosting Service tell me who is visiting my Web site and what people are looking at but not who is looking at what, (In January of this year I discovered there are raw Web log files containing this information but my Web Hosting Service does not keep backup log files older than the previous month.)

I am including an example of the detailed Web log data; it's understandable why my Web Hosting Service abstracts it into a less detailed form.

The article being referenced is **Unit Vector Math for 3D Graphics**
(www.jmargolin.com/uvmath/uvmenu.htm)

Now that I can see what people are looking at I have noticed a great deal of interest in this article as well as **The Relationship between Unit Vector Rotations and Euler Angle Functions**.
(www.jmargolin.com/uvmath/euler.doc)

These articles also seem to interest military contractors like Lockheed Martin (lmco.com), Boeing (boeing.com), Northrop Grumman (northgrum.com), and SAIC (saic.hq.nasa.gov) as well as a large number of educational institutions.

Some accesses are obviously just for fun, to articles such as to **Gas Music From Jupiter**
(www.jmargolin.com/gmfj/gmfj.htm)

There are also visits from most of our national labs. I expect they are interested in **U.S. Patent 6,377,436 Microwave Transmission Using a Laser-Generated Plasma Beam Waveguide** issued April 23, 2002 to Jed Margolin.

Abstract

A directed energy beam system uses an ultra-fast laser system, such as one using a titanium-sapphire infrared laser, to produce a thin ionizing beam through the atmosphere. The beam is moved in either a circular or rectangular fashion to produce a conductive shell to act as a waveguide for microwave energy. Because the waveguide is produced by a plasma it is called a plasma beam waveguide. The directed energy beam system can be used as a weapon, to provide power to an unmanned aerial vehicle (UAV) such as for providing communications in a cellular telephone system, or as an ultra-precise radar system.

There is a possibility that this device could be used to make a linear Tokamak.
(www.jmargolin.com/debs/debs.htm)

Conclusion

I realize this is a great deal of material to wade through, but I would appreciate confirmation that you have received it and, if possible, an estimate as to when I can expect to hear NASA's decision on this claim.

Hopefully, then we can discuss compensation. The '724 patent is available for sale if NASA wishes to purchase it to avoid setting the precedent of the U.S. Government paying compensation for each flight of an aircraft using my patent. (I don't think this would be popular with DOD.) I expect that the first UAV to crash due to Pilot Induced Oscillation (or just Flight Computer Induced Oscillation, as occurred in the first flight of the Predator) would cost more than the cost of buying my patent. I believe this patent also has commercial applications like using UAVs for traffic reporting and in Law Enforcement so your Commercialization Department may be able to generate income with it.

Sincerely yours,

Jed Margolin

Jed Margolin

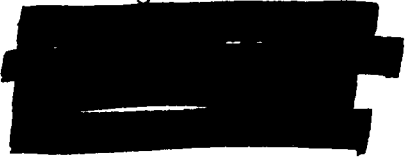

b(6)

Here are NASA's visits to my Web site:

June 2001

nasa.gov

Total hits	Files	Pageview	Bytes sent	Hostname
2 0.02%	1	2	73232 0.02%	dhcp161-117.hst.nasa.gov

July 2001

nasa.gov

Total hits	Files	Pageview	Bytes sent	Hostname
24 0.27%	24	1	216909 0.08%	aavigil1.wff.nasa.gov
1 0.01%	1	1	96274 0.04%	antonius-dekorte-pc.jpl.nasa.gov
25 0.28%	25	2	313183 0.11%	

August 2001

nasa.gov

Total hits	Files	Pageview	Bytes sent	Hostname
------------	-------	----------	------------	----------

02136

40	0.38%	40	1	184514	0.06%	time2burn.larc.nasa.gov
24	0.23%	24	1	216909	0.07%	gerhard.gsfc.nasa.gov
64	0.61%	64	2	401423	0.12%	

October 2001

nasa.gov

Total hits	Files	Pageview	Bytes sent	Hostname
1	0.01%	1	1	549657 0.11% halljm.nsstc.nasa.gov

November 2001

nasa.gov

Total hits	Files	Pageview	Bytes sent	Hostname
48	0.39%	24	2	216909 0.06% aavigill.wff.nasa.gov
42	0.34%	42	1	532111 0.14% mac01291100705.jpl.nasa.gov
1	0.01%	1	1	21505 0.01% dhcp-78-14-233.jpl.nasa.gov
91	0.73%	67	4	770525 0.21%

December 2001

nasa.gov

Total hits	Files	Pageview	Bytes sent	Hostname
1	0.01%	1	1	90494 0.01% pgrant.arc.nasa.gov

February 2002

nasa.gov

Total hits	Files	Pageview	Bytes sent	Hostname
1	0.01%	1	0	120832 0.03% csmad-nt-23.jpl.nasa.gov
1	0.01%	1	1	504805 0.11% cielo2k.jpl.nasa.gov
2	0.01%	2	1	625637 0.13%

March 2002

nasa.gov

Total hits	Files	Pageview	Bytes sent	Hostname
58	0.35%	45	5	319389 0.05% fantasy.arc.nasa.gov
6	0.04%	5	4	1299302 0.22% fryepc.larc.nasa.gov
1	0.01%	1	0	120832 0.02% shum.larc.nasa.gov

65 0.39% 51 9 1739523 0.29%

April 2002

nasa.gov

Total hits	Files	Pageview	Bytes sent	Hostname
40 0.23%	40	1	184514 0.03%	cevennes.jpl.nasa.gov
7 0.04%	7	2	45302 0.01%	doppler.jpl.nasa.gov
1 0.01%	1	1	5735 0.00%	math.jpl.nasa.gov
1 0.01%	1	0	120832 0.02%	k-137-78-152-182.jpl.nasa.gov
49 0.29%	49	4	356383 0.06%	

May 2002

nasa.gov

Total hits	Files	Pageview	Bytes sent	Hostname
4 0.02%	0	0	0 0.00%	k1505776.ksc.nasa.gov
1 0.00%	1	0	120832 0.02%	manzanita-227-215.arc.nasa.gov
1 0.00%	1	1	96274 0.02%	seraph3.lerc.nasa.gov
6 0.03%	2	1	217106 0.03%	

June 2002

nasa.gov

Total hits	Files	Pageview	Bytes sent	Hostname
3 0.02%	1	1	96694 0.02%	micronovich.gsfc.nasa.gov

July 2002

nasa.gov

Total hits	Files	Pageview	Bytes sent	Hostname
43 0.19%	43	4	190275 0.03%	seraph3.lerc.nasa.gov
42 0.19%	42	3	189552 0.03%	varies01113104503.jpl.nasa.gov
2 0.01%	2	2	7802 0.00%	paulafinlayson-pc-pentium.jpl.nasa.gov
1 0.00%	1	1	350096 0.06%	brodbell1.gsfc.nasa.gov
1 0.00%	1	1	93686 0.02%	poes12.gsfc.nasa.gov
89 0.39%	89	11	831411 0.14%	

August 2002

nasa.gov

Total hits	Files	Pageview	Bytes sent	Hostname
24 0.11%	24	1	216909 0.03%	envision.arc.nasa.gov

2138

1	0.00%	1	1	90494	0.01%		pc02141110149.jpl.nasa.gov
1	0.00%	1	1	142144	0.02%		tizzie.nsstc.nasa.gov

26	0.12%	26	3	449547	0.06%		
----	-------	----	---	--------	-------	--	--

September 2002

nasa.gov

Total hits	Files	Pageview	Bytes sent	Hostname
------------	-------	----------	------------	----------

5	0.02%	1	0	121528	0.02%		knepper.ivv.nasa.gov
1	0.00%	1	0	285696	0.04%		seraph2.lerc.nasa.gov
1	0.00%	1	0	120832	0.02%		webproxy2.dfrc.nasa.gov

7	0.03%	3	0	528056	0.08%		
---	-------	---	---	--------	-------	--	--

October 2002

nasa.gov

Total hits	Files	Pageview	Bytes sent	Hostname
------------	-------	----------	------------	----------

98	0.45%	98	14	827297	0.11%		dial37.jsc.nasa.gov
1	0.00%	1	1	49690	0.01%		isdn-dial-050.gsfc.nasa.gov
1	0.00%	1	0	120832	0.02%		latema.jpl.nasa.gov
1	0.00%	1	0	285696	0.04%		dkiewicz-pc.jpl.nasa.gov

101	0.47%	101	15	1283515	0.16%		
-----	-------	-----	----	---------	-------	--	--

November 2002

nasa.gov

Total hits	Files	Pageview	Bytes sent	Hostname
------------	-------	----------	------------	----------

27	0.12%	25	1	506284	0.06%		ntserve.gdsc.nasa.gov
7	0.03%	7	2	45342	0.01%		ecn1950165.gsfc.nasa.gov
2	0.01%	2	2	1155686	0.15%		zebra.arc.nasa.gov
1	0.00%	1	1	350096	0.04%		norton.gsfc.nasa.gov

37	0.17%	35	6	2057408	0.26%		
----	-------	----	---	---------	-------	--	--

December 2002

nasa.gov

Total hits	Files	Pageview	Bytes sent	Hostname
------------	-------	----------	------------	----------

7	0.03%	7	2	45269	0.01%		ws196.gsfc.nasa.gov
---	-------	---	---	-------	-------	--	---------------------

January 2003

nasa.gov

Total hits	Files	Pageview	Bytes sent	Hostname
------------	-------	----------	------------	----------

2 0.01% 2 2 29129 0.00% | csg- 686.cdsc.nasa.gov

February 2003

nasa.gov

Total hits	Files	Pageview	Bytes sent	Hostname
------------	-------	----------	------------	----------

2	0.01%	2	2	29138 0.00% odinssc609337.ssc.nasa.gov
---	-------	---	---	--

April 2003

nasa.gov

Total hits	Files	Pageview	Bytes sent	Hostname
------------	-------	----------	------------	----------

40	0.17%	40	1	184514 0.02% khgmac.larc.nasa.gov
8	0.03%	5	4	40212 0.00% kid-emillerw2k.saic.hq.nasa.gov
5	0.02%	1	0	121528 0.01% psycho.larc.nasa.gov
4	0.02%	3	3	63471 0.01% b03042144127.jpl.nasa.gov
3	0.01%	3	3	29881 0.00% seraph2.grc.nasa.gov

60	0.25%	52	11	439606 0.05%
----	-------	----	----	--------------

Example of Detailed Web Log Data

This is an example of the detailed Web log data, so it's understandable why my Web Hosting Service abstracts it into a less detailed form.

The article being referenced is Unit Vector Math for 3D Graphics (www.jmargolin.com/uvmath/uvmenu.htm)

khgmac.larc.nasa.gov - - [01/Apr/2003:09:32:14 -0500] "GET /uvmath/fig1.gif HTTP/1.1" 200 2590
 "http://www.jmargolin.com/uvmath/uvmath.htm" "Mozilla/4.0 (compatible; MSIE 6.0; Windows NT 5.0; Q312461; .NET CLR 1.0.3705)"

khgmac.larc.nasa.gov - - [01/Apr/2003:09:32:14 -0500] "GET /uvmath/m1.gif HTTP/1.1" 200 2237
 "http://www.jmargolin.com/uvmath/uvmath.htm" "Mozilla/4.0 (compatible; MSIE 6.0; Windows NT 5.0; Q312461; .NET CLR 1.0.3705)"

khgmac.larc.nasa.gov - - [01/Apr/2003:09:32:14 -0500] "GET /uvmath/m2.gif HTTP/1.1" 200 1464
 "http://www.jmargolin.com/uvmath/uvmath.htm" "Mozilla/4.0 (compatible; MSIE 6.0; Windows NT 5.0; Q312461; .NET CLR 1.0.3705)"

khgmac.larc.nasa.gov - - [01/Apr/2003:09:32:14 -0500] "GET /uvmath/m3.gif HTTP/1.1" 200 715
 "http://www.jmargolin.com/uvmath/uvmath.htm" "Mozilla/4.0 (compatible; MSIE 6.0; Windows NT 5.0; Q312461; .NET CLR 1.0.3705)"

khgmac.larc.nasa.gov - - [01/Apr/2003:09:32:14 -0500] "GET /uvmath/m4.gif HTTP/1.1" 200 1720
 "http://www.jmargolin.com/uvmath/uvmath.htm" "Mozilla/4.0 (compatible; MSIE 6.0; Windows NT 5.0; Q312461; .NET CLR 1.0.3705)"

khgmac.larc.nasa.gov - - [01/Apr/2003:09:32:14 -0500] "GET /uvmath/m5.gif HTTP/1.1" 200 1738
"http://www.jmargolin.com/uvmath/uvmath.htm" "Mozilla/4.0 (compatible; MSIE 6.0; Windows NT 5.0; Q312461; .NET CLR 1.0.3705)"

khgmac.larc.nasa.gov - - [01/Apr/2003:09:32:14 -0500] "GET /uvmath/m7.gif HTTP/1.1" 200 1549
"http://www.jmargolin.com/uvmath/uvmath.htm" "Mozilla/4.0 (compatible; MSIE 6.0; Windows NT 5.0; Q312461; .NET CLR 1.0.3705)"

khgmac.larc.nasa.gov - - [01/Apr/2003:09:32:14 -0500] "GET /uvmath/m8.gif HTTP/1.1" 200 1939
"http://www.jmargolin.com/uvmath/uvmath.htm" "Mozilla/4.0 (compatible; MSIE 6.0; Windows NT 5.0; Q312461; .NET CLR 1.0.3705)"

khgmac.larc.nasa.gov - - [01/Apr/2003:09:32:14 -0500] "GET /uvmath/m6.gif HTTP/1.1" 200 1762
"http://www.jmargolin.com/uvmath/uvmath.htm" "Mozilla/4.0 (compatible; MSIE 6.0; Windows NT 5.0; Q312461; .NET CLR 1.0.3705)"

khgmac.larc.nasa.gov - - [01/Apr/2003:09:32:14 -0500] "GET /uvmath/m9.gif HTTP/1.1" 200 4152
"http://www.jmargolin.com/uvmath/uvmath.htm" "Mozilla/4.0 (compatible; MSIE 6.0; Windows NT 5.0; Q312461; .NET CLR 1.0.3705)"

khgmac.larc.nasa.gov - - [01/Apr/2003:09:32:14 -0500] "GET /uvmath/m10.gif HTTP/1.1" 200 2732
"http://www.jmargolin.com/uvmath/uvmath.htm" "Mozilla/4.0 (compatible; MSIE 6.0; Windows NT 5.0; Q312461; .NET CLR 1.0.3705)"

khgmac.larc.nasa.gov - - [01/Apr/2003:09:32:14 -0500] "GET /uvmath/m11.gif HTTP/1.1" 200 2572
"http://www.jmargolin.com/uvmath/uvmath.htm" "Mozilla/4.0 (compatible; MSIE 6.0; Windows NT 5.0; Q312461; .NET CLR 1.0.3705)"

khgmac.larc.nasa.gov - - [01/Apr/2003:09:32:14 -0500] "GET /uvmath/m12.gif HTTP/1.1" 200 2580
"http://www.jmargolin.com/uvmath/uvmath.htm" "Mozilla/4.0 (compatible; MSIE 6.0; Windows NT 5.0; Q312461; .NET CLR 1.0.3705)"

khgmac.larc.nasa.gov - - [01/Apr/2003:09:32:14 -0500] "GET /uvmath/m13.gif HTTP/1.1" 200 3915
"http://www.jmargolin.com/uvmath/uvmath.htm" "Mozilla/4.0 (compatible; MSIE 6.0; Windows NT 5.0; Q312461; .NET CLR 1.0.3705)"

khgmac.larc.nasa.gov - - [01/Apr/2003:09:32:14 -0500] "GET /uvmath/m14.gif HTTP/1.1" 200 2591
"http://www.jmargolin.com/uvmath/uvmath.htm" "Mozilla/4.0 (compatible; MSIE 6.0; Windows NT 5.0; Q312461; .NET CLR 1.0.3705)"

khgmac.larc.nasa.gov - - [01/Apr/2003:09:32:14 -0500] "GET /uvmath/m15.gif HTTP/1.1" 200 2224
"http://www.jmargolin.com/uvmath/uvmath.htm" "Mozilla/4.0 (compatible; MSIE 6.0; Windows NT 5.0; Q312461; .NET CLR 1.0.3705)"

khgmac.larc.nasa.gov - - [01/Apr/2003:09:32:14 -0500] "GET /uvmath/m16.gif HTTP/1.1" 200 1858
"http://www.jmargolin.com/uvmath/uvmath.htm" "Mozilla/4.0 (compatible; MSIE 6.0; Windows NT 5.0; Q312461; .NET CLR 1.0.3705)"

khgmac.larc.nasa.gov - - [01/Apr/2003:09:32:14 -0500] "GET /uvmath/m17.gif HTTP/1.1" 200 1742
"http://www.jmargolin.com/uvmath/uvmath.htm" "Mozilla/4.0 (compatible; MSIE 6.0; Windows NT 5.0; Q312461; .NET CLR 1.0.3705)"

khgmac.larc.nasa.gov - - [01/Apr/2003:09:32:14 -0500] "GET /uvmath/m18.gif HTTP/1.1" 200 2642
"http://www.jmargolin.com/uvmath/uvmath.htm" "Mozilla/4.0 (compatible; MSIE 6.0; Windows NT 5.0; Q312461; .NET CLR 1.0.3705)"

khgmac.larc.nasa.gov - - [01/Apr/2003:09:32:14 -0500] "GET /uvmath/m19.gif HTTP/1.1" 200 1738
"http://www.jmargolin.com/uvmath/uvmath.htm" "Mozilla/4.0 (compatible; MSIE 6.0; Windows NT 5.0; Q312461; .NET CLR 1.0.3705)"

khgmac.larc.nasa.gov - - [01/Apr/2003:09:32:14 -0500] "GET /uvmath/m20.gif HTTP/1.1" 200 1762
"http://www.jmargolin.com/uvmath/uvmath.htm" "Mozilla/4.0 (compatible; MSIE 6.0; Windows NT 5.0; Q312461; .NET CLR 1.0.3705)"

khgmac.larc.nasa.gov - - [01/Apr/2003:09:32:14 -0500] "GET /uvmath/m21.gif HTTP/1.1" 200 1696
"http://www.jmargolin.com/uvmath/uvmath.htm" "Mozilla/4.0 (compatible; MSIE 6.0; Windows NT 5.0; Q312461; .NET CLR 1.0.3705)"

khgmac.larc.nasa.gov - - [01/Apr/2003:09:32:15 -0500] "GET /uvmath/m22.gif HTTP/1.1" 200 2224
"http://www.jmargolin.com/uvmath/uvmath.htm" "Mozilla/4.0 (compatible; MSIE 6.0; Windows NT 5.0; Q312461; .NET CLR 1.0.3705)"

khgmac.larc.nasa.gov - - [01/Apr/2003:09:32:15 -0500] "GET /uvmath/m23.gif HTTP/1.1" 200 1858
"http://www.jmargolin.com/uvmath/uvmath.htm" "Mozilla/4.0 (compatible; MSIE 6.0; Windows NT 5.0; Q312461; .NET CLR 1.0.3705)"

khgmac.larc.nasa.gov - - [01/Apr/2003:09:32:15 -0500] "GET /uvmath/m24.gif HTTP/1.1" 200 1711
"http://www.jmargolin.com/uvmath/uvmath.htm" "Mozilla/4.0 (compatible; MSIE 6.0; Windows NT 5.0; Q312461; .NET CLR 1.0.3705)"

khgmac.larc.nasa.gov - - [01/Apr/2003:09:32:15 -0500] "GET /uvmath/fig6.gif HTTP/1.1" 200 3304
"http://www.jmargolin.com/uvmath/uvmath.htm" "Mozilla/4.0 (compatible; MSIE 6.0; Windows NT 5.0; Q312461; .NET CLR 1.0.3705)"

khgmac.larc.nasa.gov - - [01/Apr/2003:09:32:15 -0500] "GET /uvmath/fig7.gif HTTP/1.1" 200 995
"http://www.jmargolin.com/uvmath/uvmath.htm" "Mozilla/4.0 (compatible; MSIE 6.0; Windows NT 5.0; Q312461; .NET CLR 1.0.3705)"

khgmac.larc.nasa.gov - - [01/Apr/2003:09:32:15 -0500] "GET /uvmath/fig8.gif HTTP/1.1" 200 4441
"http://www.jmargolin.com/uvmath/uvmath.htm" "Mozilla/4.0 (compatible; MSIE 6.0; Windows NT 5.0; Q312461; .NET CLR 1.0.3705)"

khgmac.larc.nasa.gov - - [01/Apr/2003:09:32:15 -0500] "GET /uvmath/fig11.gif HTTP/1.1" 200 3186
"http://www.jmargolin.com/uvmath/uvmath.htm" "Mozilla/4.0 (compatible; MSIE 6.0; Windows NT 5.0; Q312461; .NET CLR 1.0.3705)"

khgmac.larc.nasa.gov - - [01/Apr/2003:09:32:15 -0500] "GET /uvmath/fig12.gif HTTP/1.1" 200 3743
"http://www.jmargolin.com/uvmath/uvmath.htm" "Mozilla/4.0 (compatible; MSIE 6.0; Windows NT 5.0; Q312461; .NET CLR 1.0.3705)"

khgmac.larc.nasa.gov - - [01/Apr/2003:09:32:15 -0500] "GET /uvmath/fig14.gif HTTP/1.1" 200 1936
"http://www.jmargolin.com/uvmath/uvmath.htm" "Mozilla/4.0 (compatible; MSIE 6.0; Windows NT 5.0; Q312461; .NET CLR 1.0.3705)"

khgmac.larc.nasa.gov - - [01/Apr/2003:09:32:15 -0500] "GET /uvmath/fig16.jpg HTTP/1.1" 200 61706
"http://www.jmargolin.com/uvmath/uvmath.htm" "Mozilla/4.0 (compatible; MSIE 6.0; Windows NT 5.0; Q312461; .NET CLR 1.0.3705)"

khgmac.larc.nasa.gov - - [01/Apr/2003:09:32:15 -0500] "GET /uvmath/m25.gif HTTP/1.1" 200 1358
"http://www.jmargolin.com/uvmath/uvmath.htm" "Mozilla/4.0 (compatible; MSIE 6.0; Windows NT 5.0; Q312461; .NET CLR 1.0.3705)"

khgmac.larc.nasa.gov - - [01/Apr/2003:09:32:15 -0500] "GET /uvmath/m26.gif HTTP/1.1" 200 1413
"http://www.jmargolin.com/uvmath/uvmath.htm" "Mozilla/4.0 (compatible; MSIE 6.0; Windows NT 5.0; Q312461; .NET CLR 1.0.3705)"

khgmac.larc.nasa.gov - - [01/Apr/2003:09:32:15 -0500] "GET /uvmath/m27.gif HTTP/1.1" 200 1052
"http://www.jmargolin.com/uvmath/uvmath.htm" "Mozilla/4.0 (compatible; MSIE 6.0; Windows NT 5.0; Q312461; .NET CLR 1.0.3705)"

khgmac.larc.nasa.gov - - [01/Apr/2003:09:32:15 -0500] "GET /uvmath/m28.gif HTTP/1.1" 200 1017
"http://www.jmargolin.com/uvmath/uvmath.htm" "Mozilla/4.0 (compatible; MSIE 6.0; Windows NT 5.0; Q312461; .NET CLR 1.0.3705)"

khgmac.larc.nasa.gov - - [01/Apr/2003:09:32:15 -0500] "GET /uvmath/m29.gif HTTP/1.1" 200 1673
"http://www.jmargolin.com/uvmath/uvmath.htm" "Mozilla/4.0 (compatible; MSIE 6.0; Windows NT 5.0; Q312461; .NET CLR 1.0.3705)"

khgmac.larc.nasa.gov - - [01/Apr/2003:09:32:15 -0500] "GET /uvmath/m30.gif HTTP/1.1" 200 2224
"http://www.jmargolin.com/uvmath/uvmath.htm" "Mozilla/4.0 (compatible; MSIE 6.0; Windows NT 5.0; Q312461; .NET CLR 1.0.3705)"

khgmac.larc.nasa.gov - - [01/Apr/2003:09:32:24 -0500] "GET /uvmath/uvmath.htm HTTP/1.1" 200 40231
"http://www.google.com/search?q=%22euler+angle%22+normal+openGL&hl=en&lr=&ie=UTF-8&oe=UTF-8&start=10&sa=N" "Mozilla/4.0 (compatible; MSIE 6.0; Windows NT 5.0; Q312461; .NET CLR 1.0.3705)"

khgmac.larc.nasa.gov - - [01/Apr/2003:09:32:24 -0500] "GET /uvmath/fig3.gif HTTP/1.1" 200 2524
"http://www.jmargolin.com/uvmath/uvmath.htm" "Mozilla/4.0 (compatible; MSIE 6.0; Windows NT 5.0; Q312461; .NET CLR 1.0.3705)"

--end

Jed Margolin

June 17, 2003

b(6)

Mr. Alan J. Kennedy
Director, Infringement Division
Office of the Associate General Counsel
National Aeronautics and Space Administration
Headquarters
Washington, DC 20546-0001

Attn: GP(02-37016)

Dear Mr. Kennedy,

I have received your letter dated June 11, 2003.

In my contacts with NASA personnel I have repeatedly stressed my desire that this matter be resolved in a friendly manner. However, since NASA has rejected my request to consider a license proffer and in view of your letter of June 11, it is clear that NASA has decided to handle this in an adversarial manner.

Before I respond to your letter in detail, I want to make things easier for me by withdrawing my U.S. Patent **5,566,073 Pilot Aid Using a Synthetic Environment** from this administrative claim in order to focus more directly on NASA's infringement of my U.S. Patent **5,904,724 Method and Apparatus For Remotely Piloting an Aircraft**. However, I reserve the right to file a claim concerning the '073 patent at a later time.

(1) The identification of all claims of the patent(s) alleged to be infringed.

As I stated in my email of May 13, 2003 to Mr. Hammerle of LARC and in my fax of June 7, 2003 to you, I have no way of determining exactly which claims the X-38 project may have infringed unless NASA makes a full and complete disclosure to me of that project. I also have no way of determining if NASA has (or has had) other projects that also infringe on my patent unless NASA makes a full and complete disclosure of those projects as well.

Therefore, in order to answer your question, I must request that NASA make a full and complete disclosure to me of the X-38 project as well as any other current or past projects that may infringe on my patent.

If this information requires a security clearance (I have none) I suggest you start the required security investigation immediately. If there is further information that you require in this regard feel free to contact me.

- (2) *The identification of all procurements known to the claimant or patent owner which involve the alleged infringing item or process, including the identity of the vendor or contractor and the Government procuring activity.*

As I stated in my fax to you of June 7, 2003, I became aware that NASA was using synthetic vision in the X-38 project in the January 2003 issue of NASA Tech Briefs, page 40, "**Virtual Cockpit Window for a Windowless Aerospacecraft**". The article is available at:
<http://www.nasatech.com/Briefs/Jan03/MSC23096.html>

This led me to Rapid Imaging Software, Inc. and their press release (<http://www.landform.com/pages/PressReleases.htm>) which states:

"On December 13th, 2001, Astronaut Ken Ham successfully flew the X-38 from a remote cockpit using LandForm VisualFlight as his primary situation awareness display in a flight test at Edwards Air Force Base, California. This simulates conditions of a real flight for the windowless spacecraft, which will eventually become NASA's Crew Return Vehicle for the ISS. We believe that this is the first test of a hybrid synthetic vision system which combines nose camera video with a LandForm synthetic vision display. Described by astronauts as 'the best seat in the house', the system will ultimately make space travel safer by providing situation awareness during the landing phase of flight."

The RIS press release provided a link to an article in *Aviation Week & Space Technology*:
http://www.aviationnow.com/avnow/news/channel_space.jsp?view=story&id=news/sx381211.xml

As a result of more searching I discovered a link to a Johnson Space Center SBIR Phase II award to Rapid Imaging Systems at <http://sbir.gsfc.nasa.gov/SBIR/successes/ss/9-058text.html>.

It includes a particularly relevant paragraph:

The Advanced Flight Visualization Toolkit (VisualFlight™) project is developing a suite of virtual reality immersive telepresence software tools which combine the real-time flight simulation abilities with the data density of a Geographic Information System (GIS). This technology is used for virtual reality training of crews, analysis of flight test data, and as an on-board immersive situation display. It will also find application as a virtual cockpit, and in teleoperation of remotely piloted vehicles.

The emphasis on *virtual reality immersive telepresence* and *teleoperation of remotely piloted vehicles* is mine.

A search of the SBIR archive shows the following entries.

For 2001 Phase I:
 Rapid Imaging Software, Inc.

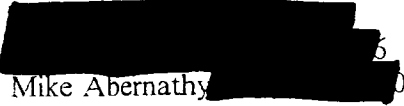
 Mike Abernathy
 01 H6.02-8715 JSC
 Integrated Video for Synthetic Vision Systems

b(6)

02145

For 2001 Phase II:
 Rapid Imaging Software, Inc.

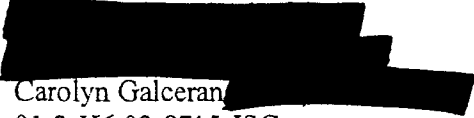
 Carolyn Galceran
 01-2-H6.02-8715 JSC

b(6)

Since my sources of information are limited to those available to the public (magazines such as *Aviation Week & Space Technology* as well as whatever I can find on the Internet) I have no way of knowing if there are other procurements, vendors, contractors, and Government procuring activity related to Claim I-222.

I believe that NASA is in a better position to know what it is (or has been) working on than I am.

- (3) *A detailed identification of the accused articles or processes, particularly where the article or process relates to a component or subcomponent of the item procured, an element by element comparison of the representative claims with the accused article or process. If available, this identification should include documentation and drawings to illustrate the accused article or process in suitable detail to enable verification of the infringement comparison.*

I believe I have answered this in section (2) as much as I am able to without NASA's cooperation.

- (4) *The names and addresses of all past and present licenses under the patent(s), and copies of all license agreements and releases involving the patent.*

There are no past licenses for this patent, and as of this date there are no present licenses for this patent. Naturally, I reserve the right to license this patent in the future as I see fit.

- (5) *A brief description of all litigation in which the patent(s) has been or is now involved, and the present status thereof.*

There has been no past litigation involving this patent, and as of this date there is no present litigation regarding this patent.

- (6) *A list of all persons to whom notices of infringement have been sent, including all departments and agencies of the Government, and a statement of the ultimate disposition of each.*

As of this date NASA is the only agency or department of the Government against which I have filed a claim.

5/11/03 – sent email to comments@hq.nasa.gov

*I believe that NASA may have infringed on one or more of my U.S. Patents.
How do I file a claim and whom do I contact?*

5/11/03 – Received reply:

Date: Sun, 11 May 2003 17:48:46 -0400 (EDT)
 From: "PAO Comments" <comments@bolg.public.hq.nasa.gov>
 Message-ID: <200305112148.h4BLmkhJ011314@bolg.public.hq.nasa.gov>
 To: [REDACTED] b(6)
 Subject: Thank you for your email.

Thank you for your message to the NASA Home Page. The Internet Service Group will attempt to answer all e-mail regarding the site, but cannot guarantee a response by a particular time. The group will not be able to answer general inquiries regarding NASA, which should instead be sent to public-inquiries@hq.nasa.gov

 5/11/03 – Sent email to <public-inquiries@hq.nasa.gov>

*I believe that NASA may have infringed on one or more of my U.S. Patents.
How do I file a claim and whom do I contact?*

Jed Margolin

As far as I can tell I did not receive a response.

 5/12/03 – Sent email to [REDACTED] (found on Web site)

b(6)

*I believe that NASA may have infringed on one or more of my U.S. Patents
How do I file a claim and whom do I contact?
(Or is my only recourse to sue in Federal Court?)*

Jed Margolin

5/12/03 – Received reply:

Mr. Margolin,

Thank you for contacting NASA with your concerns. I have referred this matter to the Patent Counsel Office, and they will be contacting you to work with you on this issue.

*Best wishes,
Jesse Midgett*

5/12/03 – Given my experience with trying to contact Government officials via email (or mail, or fax) I hadn't waited for the reply from J. Midgett. I had found the web site for the LARC (NASA Langley) Patent Counsel Office, and called up. I was connected to Kurt Hammerle and we had a nice talk. I sent him an email the next day (May 13, 2003).

I received a phone call from Barry Gibbens [REDACTED] who, apparently, was calling because of my email to J.C.Midgett and hadn't seen the email I sent to K. Hammerle. (I explained to him what I had done.) We had a nice talk. He said he had already sent me a letter. b(6)

I received his letter and sent a reply on May 18, 2003 (USPS), adding to the email I had sent K. Hammerle.

Thursday, June 5, 2003 – Received message from B. Gibbens, asking me to call him because I should contact Alan Kennedy at NASA Headquarters [REDACTED] b(6)

Friday, June 6, 2003 - I called B. Gibbens. Then I called A. Kennedy but he was out.

Saturday, June 7, 2003 – Sent a fax to A. Kennedy. The first number I tried [REDACTED] only accepted 4 pages (out of 13). I tried a few times. Then I tried [REDACTED]. It turned out that [REDACTED] was the correct number and that [REDACTED] was another group. As a result, A. Kennedy initially only got 4 pages. b(6)

Monday, June 9, 2003 – Received message from A. Kennedy and called him back.

He had not gotten the fax so he went and found it. I learned the next day that he had only gotten 4 pages.

We had a "free and frank" discussion. I stressed that I wanted to resolve it in a friendly manner and that I preferred to have NASA buy the patent for the Government.

Tuesday, June 10, 2003 – Received a message from A. Kennedy and called him back.

He said that his Manager has turned down my request that NASA consider a license proffer and has decided to handle it as a Claim, and that the investigation would take 3-6 months.

02148

However, NASA is not the only agency or department of the Government I have contacted.

7/5/1999 Email to: [redacted] b(6)
Dr. Birckelbaw, Project Manager for the UCAV contract awarded to Boeing.

Introduced myself and asked if DARPA was interested in my patent.
Response: none

7/26/1999 USPS Mail to:
Dr. Larry Birckelbaw
Program Manager, Aerospace Systems
DARPA Tactical Technology Office

[redacted]

b(6)

Introduced myself and asked if DARPA was interested in my patent. Enclosed copy of patent.
Response: none

Office of the Secretary of Defense (OSD)
Mr. E.C. "Pete" Aldridge
Under Secretary of Defense for Acquisition, Technology, and Logistics
U.S. Department of Defense
Contact Method: Email: webmaster@acq.osd.mil
Response: none

May 3, 2002 and June 6, 2002

Army - AATD, Fort Eustice, VA.
Col. Wado Carmona, Commander
Applied Aviation and Training Directorate (AATD)
Army Aviation and Missile Command
Ft. Eustice, VA

Contact Method:
Email: Ms. Lauren L. Sebring [redacted]

b(6)

June 1, 2002

Phone Call Followup: She suggested I talk to Mr. Jack Tansey
Mr. Jack Tansey, Business Development [redacted]
Email Followup: [redacted]

b(6)

June 18, 2002
June 18, 2002

Air Force Research Laboratory (AFRL)
Dr. Barbara Wilson
Contact Method: email [redacted]
Response - none

b(6)

July 17, 2002

Air Force Research Laboratory (AFRL)
 Dr. R. Earl Good, Director,
 Directed Energy Directorate
 Air Force Research Laboratory
 Kirtland Air Force Base, NM 87117-5776
 Contact Method: [REDACTED]
 Response: none

b(6)

July 23, 2002

Department of the Air Force
 Dr. James G. Roche
 Secretary of the Air Force
 Washington, DC

Contact Method: [REDACTED]

b(6)

July 28, 2002

Response: Letter from
 Lt. General Charles F. Wald
 Deputy Chief of Staff, Air & Space Operations, USAF

August 13, 2002

- (7) *A description of Government employment or military service, if any, by the inventor and/or patent owner.*

I have never been employed by the U.S. Government (or any other government). Likewise, I have never been in military service (in the United States or elsewhere). In the interests of full disclosure, I worked for three summers (1967, 1968, 1969) at the RCA Astro-Electronics Division in Hightstown, NJ. (They had a summer job program for students.)

- (8) *A list of all Government contracts under which the inventor, patent owner, or anyone in privity with him performed work relating to the patented subject matter.*

None. I did this entirely on my own dime.

(9) *Evidence of title to the patent(s) alleged to be infringed or other right to make the claim.*

This appears to be a two-part question. Does the patent belong to Jed Margolin, and am I that Jed Margolin?

Part 1 - If you look at the front page of the '724 patent you will see that it was, indeed, issued to Jed Margolin, 3570 Pleasant Echo Dr., San Jose, CA.

If you contact the U.S. Patent and Trademark Office, Document Services Department (703-308-9726), you can order an Abstract of Title to verify that I own the patent. According to 37 CFR 1.12, assignment records are also open to public inspection at the United States Patent and Trademark Office.

Part 2 - If you look up Jed Margolin, 3570 Pleasant Echo Dr., San Jose, CA, in a telephone directory you will find assigned to it the telephone number 408-238-4564.

When you called me on June 9 and June 10, that was the number you called.

Other than my affirming that I am, indeed, the Jed Margolin in question, I can only suggest that you contact my cousin Lenny (oops, I mean Dr. Len Margolin) who is employed by Los Alamos National Laboratory, and ask him if he has a cousin Jed who is an engineer and an inventor, and who possesses the Margolin gene for being very persistent. (Some say stubborn.) The last time I saw him was in Ann Arbor, Michigan, after he had just passed the orals for his doctorate. (He bought me a beer at a place on South University.)

(10) *A copy of the Patent Office file of the patent, if available, to claimant.*

I do not have a copy of the USPTO's patent file. What I have is my prosecution file which contains, among other things, privileged communications between my patent attorney and myself.

Besides, in our telephone conversation of June 10, you stated that one of the research centers (I believe it was LARC) had already ordered the file.

(11) *Pertinent prior art known to claimant, not contained in the Patent Office file, particularly publications and foreign art.*

I have found no relevant prior art.

However, there is an interesting article in the June 2, 2003 issue of *Aviation Week & Space Technology* on pages 48-51 entitled **GA Riding 'Highway-in-the-Sky'** which describes, among other things, the work of Dennis B. Berlinger, lead scientist for flight deck research at the FAA's Civil Aeromedical Institute (CAMI) regarding what is called **Performance-Controlled Systems**. In the Specification of my '724 patent I call it **First Order RPV Flight Control Mode**. In Claim 18:

18. The station of claim 13, wherein said set of remote flight controls are configured to allow inputting absolute pitch and roll angles instead of pitch and roll rates.

An Internet search turned up Mr. Berlinger's report **Applying Performance-Controlled Systems, Fuzzy Logic, and Fly-By-Wire Controls to General Aviation** as DOT/FAA/AM-02/7.

I am pleased that Mr. Berlinger's May 2002 study confirms the value of Performance-Controlled Systems in piloted aircraft and I believe that teaching it in my '724 patent (filed January 19, 1999) gave an additional novel and useful aspect to my invention.

(The article also describes the Synthetic Vision system used in the FAA's Capstone program.)

If you have any further questions, please contact me.

Sincerely yours,



Jed Margolin

Enclosed: Response from General Wald
AWST article
Berlinger Report
U.S. Patent 5,904,724

02152

Reference 1 (1 Page)

National Aeronautics and
Space Administration
Langley Research Center
100 NASA Road
Hampton, VA 23681-2199



May 14, 2003

Reply to Attn of: 212

Jed Margolin



b(6)

Subject: Infringement Inquiry

Dear Mr. Margolin,

I received notice of your belief that NASA may have infringed one or more of your U.S. patents. In order to address your concerns, we need to receive some more detailed information. Please provide the titles and patent numbers of any patents you feel NASA may have infringed. Please also provide a description of any actions by NASA leading to your belief of possible infringement. Finally, please specify in detail how those actions constitute infringement of your patent(s). This information will allow us to evaluate your assertion and respond and/or react appropriately. Thanks for contacting us. I look forward to hearing from you soon, and discussing your concerns further.

Cordially,

A handwritten signature in cursive script, appearing to read "Barry V. Gibbens".

Barry V. Gibbens
Patent Attorney
Technology Commercialization
Program Office

Jed Margolin

[Redacted]

[Redacted]

May 18, 2003

b(6)

Mr. Barry V. Gibbens
National Aeronautics and Space Administration
Langley Research Center

[Redacted]

b(6)

Attn: 212

Dear Mr. Gibbens,

This is in response to your letter dated May 14, 2003.

As we discussed in our telephone conversation on May 16, the information you have requested was supplied in my email to Mr. Kurt Hammerle on May 12, 2003.

After I emailed my inquiry to Mr. Jesse Midgett on May 12, I discovered the web page for the Patent Counsel Office and contacted Mr. Hammerle by telephone.

I apologize for any confusion this may have created.

As a result of more searching I have discovered a link to a Johnson Space Center SBIR Phase II award to Rapid Imaging Software at <http://sbir.gsfc.nasa.gov/SBIR/successes/ss/9-058text.html>.

It includes a particularly relevant paragraph:

The Advanced Flight Visualization Toolkit (VisualFlight™) project is developing a suite of virtual reality immersive telepresence software tools which combine the real-time flight simulation abilities with the data density of a Geographic Information System (GIS). This technology is used for virtual reality training of crews, analysis of flight test data, and as an on-board immersive situation display. It will also find application as a virtual cockpit, and in teleoperation of remotely piloted vehicles.

{ The emphasis on teleoperation of remotely piloted vehicles is mine. }

A search of the SBIR archive shows the following entries.

For 2001 Phase I:

Rapid Imaging Software, Inc.

[Redacted]

Mike Abernathy

01 H6.02-8715 JSC

Integrated Video for Synthetic Vision Systems

b(6)

For 2001 Phase II:

Rapid Imaging Software, Inc.

 Carolyn Galceran

01-2-H6.02-8715 JSC

Integrated Video for Synthetic Vision Systems

b(6)

If there is any additional information regarding my patents that you would find helpful please let me know.

Sincerely yours,

Jed Margolin

Jed Margolin



NASA SBIR SUCCESSSES

INNOVATION

LandForm VisualFlight™ is the power of a geographic information system (GIS) and the speed of a flight simulator, accessible from any Windows application.

ACCOMPLISHMENTS

- The Advanced Flight Visualization Toolkit (VisualFlight™) project is developing a suite of virtual reality immersive telepresence software tools which combine the real-time flight simulation abilities with the data density of a Geographic Information System (GIS). This technology is used for virtual reality training of crews, analysis of flight test data, and as an on-board immersive situation display. It will also find application as a virtual cockpit, and in teleoperation of remotely piloted vehicles.
- AFVT will enhance the ability of analysts and operators to interact with large amounts of multidimensional data using the most natural paradigm available: 3D immersion. This operator/data interaction technology will be an advancement comparable to the invention of the Heads-Up Display (HUD). AFVT will move the HUD into the third dimension.
- A simplified user interface, it will fuse real-time 3D displays of terrain with digital maps, satellite data, vehicles, flight paths, and waypoints. This unique and innovative approach will build upon recent software technology research and development from Rapid Imaging Software. VisualFlight™ permits users to construct and deploy their own immersive multidimensional display applications on Windows-based computer platforms.

COMMERCIALIZATION

- VisualFlight™ is sold as a development kit starting with 5 run-time licenses. Users who wish to distribute more applications

Johnson Space Center
1998 Phase II

LandForm VisualFlight™

Rapid Imaging Software, Inc.

Albuquerque, NM



Optional Powerpoint file

GOVERNMENT/SCIENCE APPLICATIONS

- The firm's VisualFlight™ System was used to fly the X-38 on it's latest test flight. The flight vehicle was piloted by astronaut (Ken Ham) using LandForm VisualFlight

using LandForm VisualFlight™ technology can purchase additional run-time licenses as needed.

- VisualFlight™ 1.0 has been available to qualified users for several months now, and the response is excellent. VisualFlight™ has been deployed to display live real-time flight data broadcast over a network. Please visit this page for the latest VisualFlight™ developments.
- **LandForm V/O Video Overlay** plug-in for LandForm C3 or Flight Vision is available for the Matrox Corona board only. The price is \$4995 for a # single users license. Site license is available for \$6995.

For more information about this firm, please send e-mail to: [company representative](#)

[Return to NASA SBIR Success Listings](#)

Curator: [SBIR Support](#)

system as his digital cockpit window.

[REDACTED]

From: Rotella, Robert F. (HQ-MA000)
Sent: Thursday, January 29, 2009 12:18 PM
To: Hammerle, Kurt G. (JSC-AL)
Cc: Fein, Edward K. (JSC-AL); McNutt, Jan (HQ-MC000)
Subject: Margolin Patent

Kurt-

Would you please confirm that you have the USPTO file history for Patent No. 5,904,724 by Margolin.

We asked Helen Galus to send it to Ed when we began our review of this matter.

Thanks,
Bob

Robert F. Rotella
Senior Patent Attorney
Office of the General Counsel
NASA Headquarters

[REDACTED] b(6)

This document, including any attachments, contains information that is confidential, protected by the attorney-client or other applicable privileges, or constitutes non-public information. It is intended only for the designated recipient(s). If you are not an intended recipient of this information, please take appropriate steps to destroy this document in its entirety and notify the sender of its destruction. Use, dissemination, distribution, or reproduction of this information by unintended recipients is not authorized and may be unlawful.

[REDACTED]

From: McNutt, Jan (HQ-MC000)
Sent: Wednesday, February 11, 2009 3:01 PM
To: Hammerle, Kurt G. (JSC-AL)
Cc: Delgado, Francisco J. (JSC-ER6); Rotella, Robert F. (HQ-MA000); Borda, Gary G. (HQ-MC000); Graham, Courtney B. (HQ-MA000); Fein, Edward K. (JSC-AL)
Subject: Margolin Claim

Kurt (and Frank),

Jed Margolin sent me this document.



auvsi_answer.pdf

b(5)

[REDACTED]

Regards,

Jan S. McNutt
Senior Attorney (Commercial)
Office of the General Counsel
NASA Headquarters

[REDACTED]

b(6)

This document, including any attachments, contains information that may be confidential, protected by the attorney-client or other applicable privileges, or constitutes non-public information. All content is intended only for the designated recipient(s). If you are not an intended recipient of this information or have received this message inadvertently, please take appropriate steps to destroy this content in its entirety and notify the sender of its destruction. Use, dissemination, distribution, or reproduction of this information by unintended recipients or in a manner inconsistent with its provision is not authorized and may be unlawful.

Synthetic Vision Technology for Unmanned Aerial Systems: The Real Story

By Jed Margolin
January 7, 2009

Contents

Introduction

What is Synthetic Vision?

Digital Terrain Elevation Database

Displaying the Digital Elevation Database

NASA HiMAT

Visual-Proprioceptive Cue Conflicts in the Control of Remotely Piloted Vehicles, Reed, 1977

Simulators

When Did NASA Start Working on Synthetic Vision?

Other References cited by the AUVSI Authors

"Pathway-in-the-Sky Contact Analog Piloting Display," Knox and Leavitt, 1977

"The Electronic Terrain Map: A New Avionics Integrator", Small, D.M., 1981

"VCASS: An Approach to Visual Simulation," Kocian, 1977

U.S. Patent 5,566,073 **Pilot Aid Using A Synthetic Environment** issued October 15, 1996 to Margolin

U.S. Patent 5,904,724 **Method and apparatus for remotely piloting an aircraft** issued May 18, 1999 to Margolin

U.S. Patent Application Publication 20080033604 **System and Method For Safely Flying Unmanned Aerial Vehicles in Civilian Airspace**

The Future of Synthetic Vision

References

Introduction

This is in response to the article **Synthetic Vision Technology for Unmanned Systems: Looking Back and Looking Forward** by Jeff Fox, Michael Abernathy, Mark Draper and Gloria Calhoun which appeared in the December 2008 issue of AUVSI's Unmanned Systems (page 27). *{Ref. 1}*

The AUVSI Authors have used the term "synthetic vision" so loosely that many readers will believe it was invented long before it actually was. This is an important issue. Aerospace is a field where precision and accuracy is critical. There are also patent rights involved. In the interests of full disclosure I am the listed inventor on several patents relating to synthetic vision and there is a patent infringement disagreement between the owner of the patents (Optima Technology Group) and the company that one of the AUVSI Authors is affiliated with (Rapid Imaging Software).

What Is Synthetic Vision?

The term "Synthetic Vision" originally meant anything that you put up on a video display.

For example, there is U.S. Patent 5,593,114 **Synthetic Vision Automatic Landing System** issued January 14, 1997 to Ruhl (Assignee McDonnell Douglas Corporation). *{Ref. 2}*

From Column 2, lines 16 - 27:

The instant invention is an Enhanced or Synthetic Vision (also called Autonomous) Landing System (E/SV). This system allows the pilot to view the approach scene with the use of a forward looking radar or equivalent sensor which provides the means of identifying the runways and the airport and land the aircraft using the automatic landing systems on virtually all types of aircraft. A pilot effectively turns the flight task during zero visibility or other low visibility weather conditions into a synthetic "see to land" approach because the image from the forward looking sensor provides sufficient detail to turn any instrument landing into what appears to be a visual landing.

In this patent Enhanced or Synthetic Vision is a display of the data from a forward looking radar or equivalent sensor.

This was also the FAA's definition at the time, in their **Synthetic Vision Technology Demonstration, Volume 1 of 4, Executive Summary** *{Ref 3}*. From PDF page 10:

1.1 BACKGROUND

In 1988 the Federal Aviation Administration (FAA), in cooperation with industry, the United States Air Force (USAF), the Navy, and several other government organizations initiated an effort to demonstrate the capabilities of existing technologies to provide an image of the runway and surrounding environment for pilots operating aircraft in low visibility conditions. This effort was named the Synthetic Vision Technology Demonstration (SVTD) program. Its goal was to document and demonstrate aircraft sensor and system performance achieved with pilots using millimeter wave (MMW) radar sensors, a forward-looking infrared (FLIR) sensor, and a head-up display (HUD).

And from PDF pages 11,12:

02167

1.2. OBJECTIVE

The objective of the Synthetic Vision Technology Demonstration program was to develop, demonstrate, and document the performance of a low-visibility, visual-imaging aircraft landing system. The experimental Synthetic Vision System components included on-board imaging sensor systems using millimeter-wave and infrared technology to penetrate fog, and both head-up (HUD) and head-down (HDD) displays. The displays presented the processed raster image of the forward scene, combined with suitable avionics-based stroke symbology for the pilot's use during a manually flown approach and landing. The experimental system, sometimes referred to as a functional prototype system, included all the functions (in prototype form only) required to accomplish precision, non-precision, and non-instrument approaches and landings in low visibility weather conditions.

In the AUVSI Authors' own article they equate "pictorial format avionics" with "synthetic vision." [Paragraph 10]:

Pictorial format avionics (i.e., synthetic vision) formed a key ingredient of the Air Force Super Cockpit concept.

Boeing's report **Multi-Crew Pictorial Format Display Evaluation** *{Ref. 4}* describes what Pictorial Format means (PDF Page 17):

The Multi-Crew Pictorial format Display Evaluation Program is the third in a series of contracted efforts, sponsored primarily by the Air Force Flight Dynamics Laboratory, Crew Systems Development Branch, (AFWAL/FIGR). In the first of these efforts, conceptual displays were developed for six primary fighter crew station functions: primary flight, tactical situation, stores management, systems status, engine status, and emergency procedures (Jauer and Quinn, 1982).

In the second contract, Pictorial Format Display Evaluation (PFDE), the Boeing Military Airplane Company continued the development beyond the paper formats of the earlier program and implemented the results in a piloted simulation. Two simulation studies were conducted to evaluate the usability and acceptability of pictorial format displays for single-seat fighter aircraft; to determine whether usability and acceptability were affected by display mode -- color or monochrome; and to recommend format changes based on the simulations. In the first of the two PFDE studies, pictorial formats were implemented and evaluated for flight, tactical situation, system status, engine status, stores management, and emergency status displays. The second PFDE study concentrated on the depiction of threat data. The number of threats and the amount and type of threat information were increased. Both PFDE studies were reported in Way, Hornsby, Gilmour, Edwards and Hobbs, 1984.

Pictorial Format Avionics is pictures. That explains why it is called **Pictorial** Format Avionics.

Why can't we use the term "Synthetic Vision" to mean anything we want it to mean?

1. It is sloppy.
2. The FAA has a definition for "Synthetic Vision" and if you want an FAA type certificate for your Synthetic Vision product you have to use their definition.

{Ref. 5 – FAA current definition of synthetic vision}

Synthetic vision means a computer-generated image of the external scene topography from the perspective of the flight deck that is derived from aircraft attitude, high-precision navigation solution, and database of terrain, obstacles and relevant cultural features.

{Emphasis added}

{Ref. 6 – FAA Synthetic Vision is based on a Digital Elevation Database}

“Everyone gets their data from the same original source.”

“If accuracy of data base must be validated then SV is unapproveable.”

“Current resolution tends to round-up the elevation data so that small errors are not as significant and on the conservative side.”

{Emphasis added}

Therefore, Synthetic Vision means a computer-generated image of the external scene topography from the perspective of the flight deck that is derived from aircraft attitude, high-precision navigation solution, and digital terrain elevation database, obstacles and relevant cultural features.

Implicit in this is that in order for the external scene topography to be viewed from the perspective of the flight deck it has to be a 3D projected view and that the digital terrain elevation database must represent real terrestrial terrain, as opposed to terrain that is simply made up.

Digital Terrain Elevation Database

The **Digital Terrain Elevation Database** is also called the **Digital Elevation Database** or **Digital Elevation Model**. From Ref. 7:

The USGS Digital Elevation Model (DEM) data files are digital representations of cartographic information in a raster form. DEMs consist of a sampled array of elevations for a number of ground positions at regularly spaced intervals. These digital cartographic/geographic data files are produced by the U.S. Geological Survey (USGS) as part of the National Mapping Program and are sold in 7.5-minute, 15-minute, 2-arc-second (also known as 30-minute), and 1-degree units. The 7.5- and 15-minute DEMs are included in the large scale category while 2-arc-second DEMs fall within the intermediate scale category and 1-degree DEMs fall within the small scale category - (Source: USGS)

The Digital Elevation Model was substantially improved by STS-99 when Endeavour's international crew of seven spent 11 days in orbit during February 2000 mapping the Earth's surface with radar instruments. {Ref. 8}

Displaying the Digital Elevation Database

Now that we have a Digital Elevation Database consisting of a sampled array of elevations for a number of ground positions at regularly spaced intervals, what do we do with it? The database is just elevation points.

If you display only points there is no way to remove "hidden points" because there are no surfaces to test them against. (Things can only be hidden behind surfaces.) The result is a jumble which looks like this (the only useful features are the highest peaks):

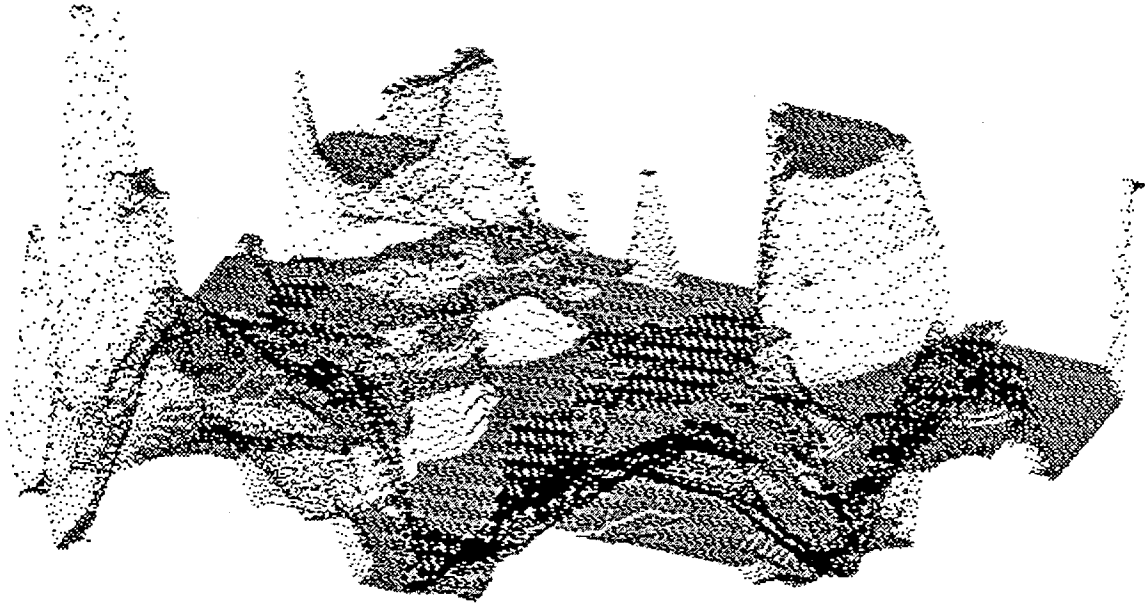

This following picture shows the same scene rendered in polygons. (The polygons are crude because I had only a few colors to work with and there is no clipping, only polygon sorting):

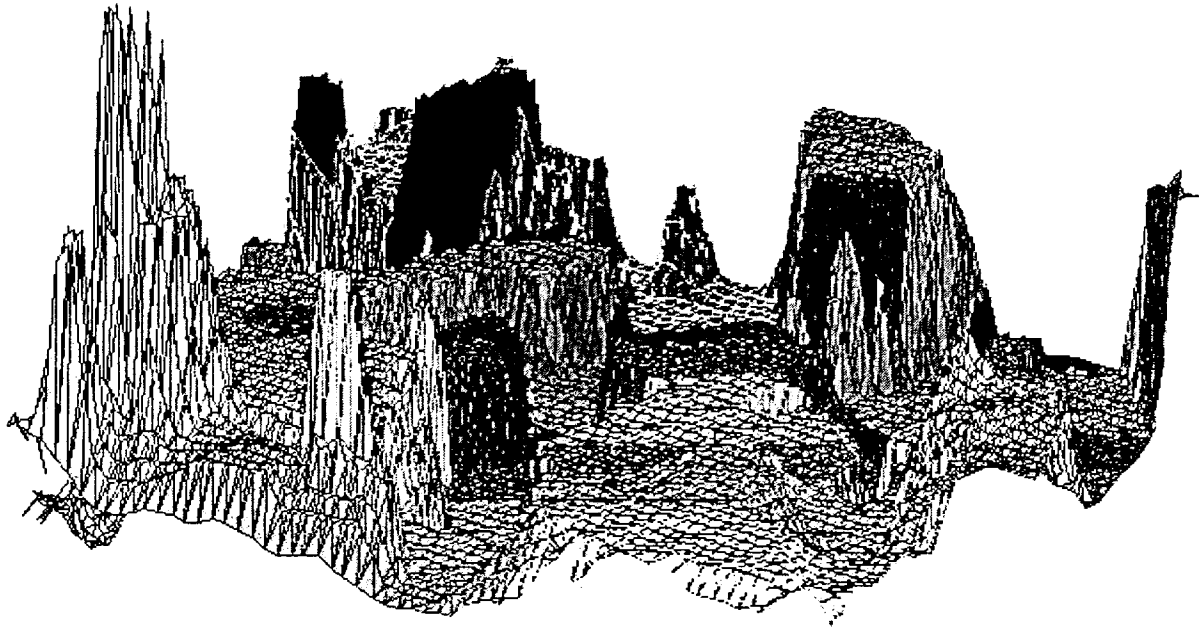

After you have used the digital elevation points to produce polygons you can shade and blend the polygons so that the underlying polygons may no longer be obvious. Honeywell did an excellent job in their IPFD (Instrument Primary Flight Display) [Ref. 9]:

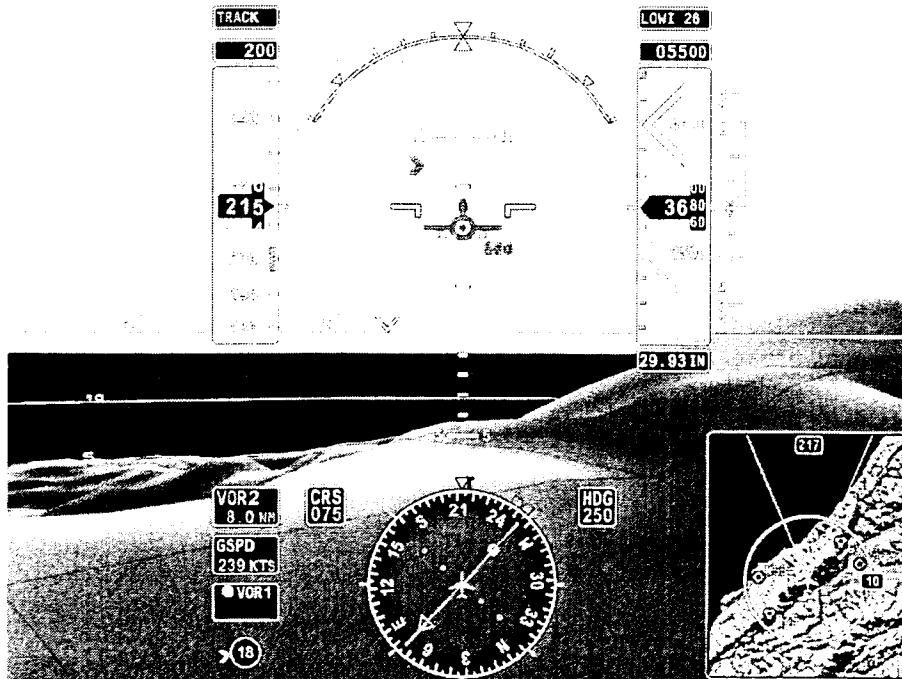

NASA HiMAT

The AUVSI Authors have gone to considerable lengths to persuade readers that NASA's HiMAT project was Synthetic Vision [Paragraphs 11 – 14]. It wasn't.

HiMAT - Summary

Sarrafian (Ref. 11)

1. "The vehicle was flown with cockpit display instruments until the landing approach phase of the flight when the camera aboard the aircraft was activated to provide the pilot with a television display during the approach."
2. During the operational phase of the HiMAT program, a simulator was used to adjust the control laws for the primary control system. The display presented to the pilot of this simulated system was a display of an instrument landing system (ILS).
3. Separately, a study was undertaken to compare evaluations of pilots using a simulated visual display of the runway scene and a simulated ILS display with the results of actual flight tests, using the HiMAT aircraft as a representative remotely piloted research vehicle.

There is no mention of a terrain database or any suggestion that the simulated visual display of the runway scene was ever used to control a real aircraft. It was never anything other than a simulation.

From Evans and Schilling {Ref. 13}:

Visual Landing Aid

Actual. - Cues to the pilot during landing included the cockpit instruments, ILS/glideslope error indicators, television transmission from the vehicle, calls on the radio from the chase pilot, and space-positioning calls from the flight-test engineer.

Simulation model. - For most of the program, the landing cues for the pilot in a HiMAT simulation included only the instruments, mapboards, and the ILS/glideslope error indicators. Although these are all valid cues, they could not achieve the same effect as the television transmission used in actual flight. During flight, as soon as the pilot can identify the runway, his scan focuses more on the television picture and less on the cockpit instruments. To help alleviate this lack of fidelity in the simulation, a display of the runways on the dry lakebed was developed on a recently purchased Evans and Sutherland Graphics System.

HiMAT Details

From NASA's description of the HiMAT project {Ref. 10}:

Highly Maneuverable Aircraft Technology

From mid-1979 to January 1983, two remotely piloted, experimental Highly Maneuverable Aircraft Technology (HiMAT) vehicles were used at the NASA Dryden Flight Research Center at Edwards, Calif., to develop high-performance fighter technologies that would be applied to later aircraft. Each aircraft was approximately half the size of an F-16 and had nearly twice the fighter's turning capability.

and, later:

The small aircraft were launched from NASA's B-52 carrier plane at an altitude of approximately 45,000 feet. Each HiMAT plane had a digital on-board computer system and was flown remotely by a NASA research pilot from a ground station with the aid of a television camera mounted in the cockpit. There was also a TF-104G chase aircraft with backup controls if the remote pilot lost ground control.

NASA's article says it was flown remotely by a pilot using a television camera in the aircraft. It does not say it was flown using what is now known as synthetic vision. (As previously explained, the definition of the term "synthetic vision" has changed over the years.)

It does say:

Dryden engineers and pilots tested the control laws for the system, developed by the contractor, in a simulation facility and then in flight, adjusting them to make the system work as intended.

and that is where the AUVSI Authors have gone astray, whether deliberately or through poor scholarship.

The AUVSI Authors cite the report by Shahan Sarrafian, "**Simulator Evaluation of a Remotely Piloted Vehicle Lateral Landing Task Using a Visual Display.**" There are two Sarrafian reports with that title, one dated May 1984; the other dated August 1984. See Ref. 11 which contains links to the reports as well as to mirrored copies. The August 1984 report has been converted to text to make it easy to search and to quote from.

The title of the Sarrafian report gives an accurate description of his project, "**Simulator Evaluation of a Remotely Piloted Vehicle Lateral Landing Task Using a Visual Display.**"

It was a simulation.

Here is the Introduction from the report. It's a little long but it describes the heart of the matter. I have underlined the parts that are especially relevant.

Introduction

The remotely piloted research vehicle (RPRV) is a tool that can be used for exploring unproven and advanced technologies without risking the life of a pilot. The flight testing of RPRVs(1) allows programs to be conducted at a low cost, in quick response to demand, or when hazardous testing is required to assure the safety of manned vehicles. Yet this type of testing must be performed by the most versatile

system available - the pilot. The pilot has the same responsibilities and tasks as if he were onboard the aircraft; this includes guiding the vehicle to a safe landing. The only difference is that he must accomplish this final task from a ground-based cockpit.

The highly maneuverable aircraft technology (HiMAT) aircraft (Fig. 1) is a remotely piloted research vehicle that has completed flight tests to demonstrate advanced fighter technologies at NASA Ames Research Center's Dryden Flight Research Facility. The HiMAT vehicle is a 0.44-scale version of an envisioned small, single-seat fighter airplane. The mission profile of HiMAT (Fig. 2) included a launch from a B-52 aircraft and the acquisition of flight test data. The vehicle was then flown by a NASA test pilot in a fixed ground-based cockpit to a horizontal landing on the Edwards dry lakebed. The vehicle was flown with cockpit display instruments until the landing approach phase of the flight when the camera aboard the aircraft was activated to provide the pilot with a television display during the approach.

During the operational phase of the HiMAT program, the lateral-stick gearing gain used in the aircraft approach was altered from a variable gain schedule (derived from simulation) to a constant gain schedule. The schedules were changed in response to pilot complaints about oversensitivity in the lateral stick that required high pilot compensation. Before the modified gain schedule was implemented into the primary control system (PCS), it was evaluated in the HiMAT simulator using an instrument landing system (ILS) display; the schedule was found to be satisfactory. Postflight comments from HiMAT pilots indicated that the handling qualities during landing approach were significantly improved as a result of the modified gain schedule.

In a separate development, a visual display that was used for engineering purposes was implemented into the simulator during the latter portion of the flight test program when simulation was no longer required to support the remaining flights. While the addition of a visual display is known to significantly improve the fidelity of a simulation system, the need for such a system in RPRV simulation at Ames Dryden was felt to be reduced since pilots had an opportunity to conduct proficiency flights with an RPRV Piper Comanche PA-30 aircraft. Nevertheless, when a visual display became available in the simulation laboratory, a decision was made to determine the effectiveness of this type of visual display in the simulation of visual RPRV flight. The RPRV evaluation described in this paper was designed to focus on the utility of a visual display of this type while studying the influence of changes in lateral-stick gearing gains of remotely piloted research vehicle handling qualities during simulated approaches and landings. This study was undertaken to compare evaluations of pilots using a simulated visual display of the runway scene and a simulated ILS display with the results of actual flight tests, using the HiMAT aircraft as a representative remotely piloted research vehicle.

What this says is:

- 1.** "The vehicle was flown with cockpit display instruments until the landing approach phase of the flight when the camera aboard the aircraft was activated to provide the pilot with a television display during the approach."
- 2.** During the operational phase of the HiMAT program, a simulator was used to adjust the control laws for the primary control system. The display presented to the pilot of this simulated system was a display of an instrument landing system (ILS).
- 3.** Separately, a study was undertaken to compare evaluations of pilots using a simulated visual display of the runway scene and a simulated ILS display with the results of actual flight tests, using the HiMAT aircraft as a representative remotely piloted research vehicle.

There is no mention of a terrain database or any suggestion that the simulated visual display of the runway scene was ever used to control a real aircraft. It was never anything other than a simulation.

Sarrafian does not show a picture of the ILS display. He probably assumed that anyone reading the report in 1984 would know what one looks like.

The following is a modern picture and an explanation of an ILS display from NASA *{Ref. 12}*. Note that the sky above the horizon line is blue; the ground below the horizon line is brown. There is no depiction of terrain. This looks a great deal like what is now known as a Primary Flight Display.

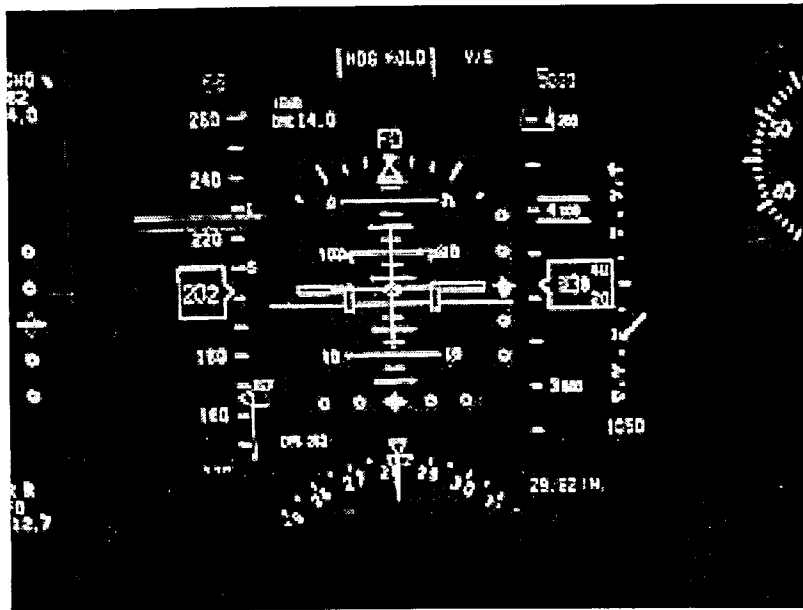

Instrument Landing System (ILS)

An aircraft on an instrument landing approach has a cockpit with computerized instrument landing equipment that receives and interprets signals being from strategically placed stations on the ground near the runway. This system includes a "Localizer" beam that uses the VOR indicator with only one radial aligned with the runway. The Localizer beam's width is from 3° to 6°. It also uses a second beam called a "glide slope" beam that gives vertical information to the pilot. The glide slope is usually 3° wide with a height of 1.4°. A horizontal needle on the VOR/ILS head indicates the aircraft's vertical position. Three marker beacons (outer, middle and inner) are located in front of the landing runway and indicate their distances from the runway threshold. The Outer Marker (OM) is 4 to 7 miles from the runway. The Middle Marker (MM) is located about 3,000 feet from the landing threshold, and the Inner Marker (IM) is located between the middle marker and the runway threshold where the landing aircraft would be 100 feet above the runway.

The VOR indicator for an ILS system uses a horizontal needle in addition to the vertical needle. When the appropriate ILS frequency is entered into the navigation radio, the horizontal needle indicates where the aircraft is in relation to the glide slope. If the needle is above the center mark on the dial, the aircraft is below the glide slope. If the needle is below the center mark on the dial, the aircraft is above the glide slope.

The following is a picture of the image Sarrafian produced in his simulator (*Figure 9 - Simulated landing approach conditions on glideslope*):

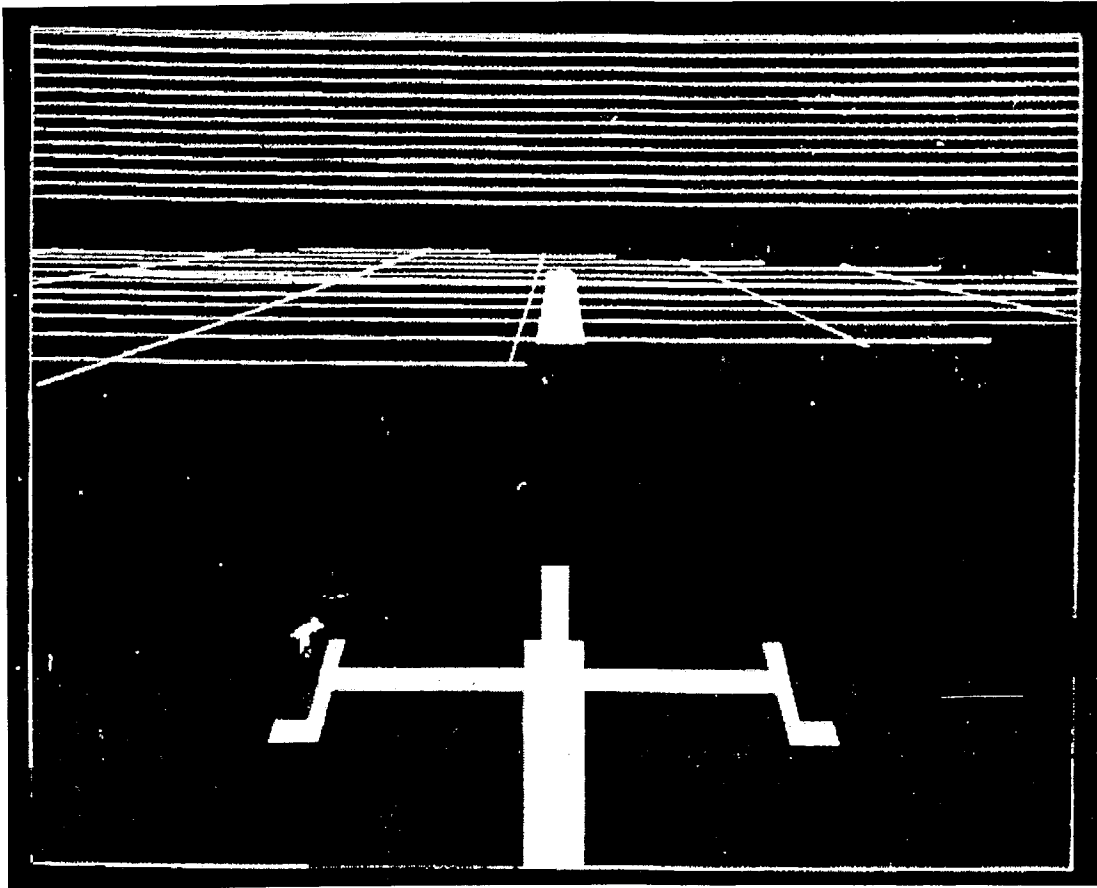

The display was created with an Evans and Sutherland Picture System [Ref. 16] using a calligraphic monitor. The term *calligraphic* means that the system only drew lines and dots. This type of system is also called *Random Scan* because the electron beam in the CRT can be moved anywhere on the screen, as opposed to a Raster Scan system, which draws a raster. Atari's term for *Random Scan* was *XY* or *Vector* and was used in several games in the late 1970s and early 1980s such as Asteroids, BattleZone, and Star Wars.

The solid areas are filled-in by drawing lots of lines.

The lines above the horizon are presumably meant to indicate the sky. The grid lines are presumably meant to indicate the ground. There is no suggestion that the grid lines are produced from a digital elevation database. There would be no reason to use a digital elevation database because the system was used only to simulate landings. (Indeed, the name of the study is "Simulator Evaluation of a Remotely Piloted Vehicle Lateral Landing Task Using a Visual Display.")

Another HiMAT report is **THE ROLE OF SIMULATION IN THE DEVELOPMENT AND FLIGHT TEST OF THE HIMAT VEHICLE** by M. B. Evans and L. J. Schilling *{Ref. 13}*.

From Evans and Schilling:

Visual Landing Aid

Actual - Cues to the pilot during landing included the cockpit instruments, ILS/glideslope error indicators, television transmission from the vehicle, calls on the radio from the chase pilot, and space-positioning calls from the flight-test engineer.

Simulation model - For most of the program, the landing cues for the pilot in a HiMAT simulation included only the instruments, mapboards, and the ILS/glideslope error indicators. Although these are all valid cues, they could not achieve the same effect as the television transmission used in actual flight. During flight, as soon as the pilot can identify the runway, his scan focuses more on the television picture and less on the cockpit instruments. To help alleviate this lack of fidelity in the simulation, a display of the runways on the dry lakebed was developed on a recently purchased Evans and Sutherland Graphics System.

HiMAT was actually flown using cockpit instruments, ILS/glideslope error indicators, television transmission from the vehicle, calls on the radio from the chase pilot, and space-positioning calls from the flight-test engineer.

It was not flown using synthetic vision.

The AUVSI Authors have reproduced a picture in their article with the caption, "The HiMAT RPV remote cockpit showing synthetic vision display. Photo courtesy of NASA."

This picture is identical to the picture in Sarrafian Figure 5 *{Ref. 11}*, August 1984, PDF page 10} but the Sarrafian picture has a different caption. It says, "HiMAT simulation cockpit."



The HiMAT RPV remote cockpit showing synthetic vision display. Photo courtesy of NASA.

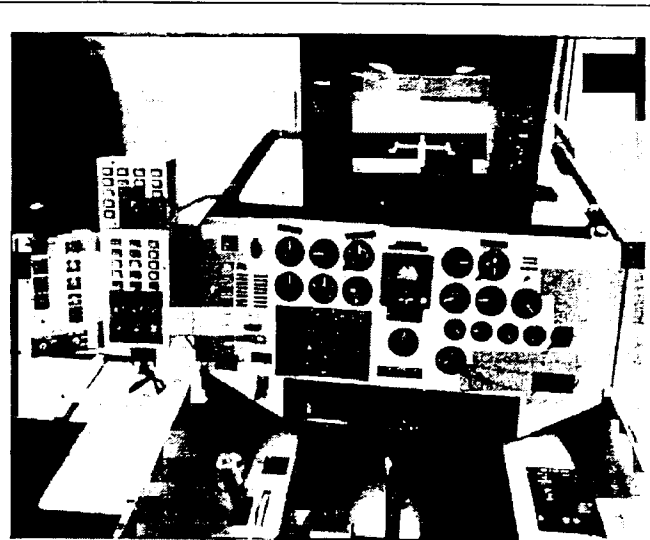

Fig. 5 HiMAT simulation cockpit.

The monitor shows a picture of the kind shown in Sarrafian Figure 8 or Figure 9 (along with a considerable amount of what appears to be reflected glare). The picture was produced by an Evans and Sutherland Picture System which requires a calligraphic monitor.

Here's the thing. "The vehicle was flown with cockpit display instruments until the landing approach phase of the flight when the camera aboard the aircraft was activated to provide the pilot with a television display during the approach."

In order to display the video from the camera aboard the aircraft, the Ground Cockpit that controlled the aircraft had to have a raster-scan monitor.

Raster-scan monitors and Calligraphic monitors are incompatible.

The picture shows the Simulation Cockpit, and the Simulation Cockpit could not be used to control the aircraft.

Why did the AUVSI Authors change the caption?

Visual-Proprioceptive Cue Conflicts in the Control of Remotely Piloted Vehicles, Reed, 1977

In paragraph 9 the AUVSI Authors state:

Also in 1979, the Air Force published research identifying human factors problems that would have to be overcome in RPV cockpit design ("Visual- Proprioceptive Cue Conflicts in the Control of Remotely Piloted Vehicles" by Reed in 1977). NASA would use this in the design of the HiMAT RPV 3D visual system in 1984.

Ref. 14 provides the link to the Reed report.

This is what the Reed report was about:

1. From page 5 (PDF page 8):

An operator is asked to maneuver a remotely piloted vehicle (RPV) from an airborne control station (a mother ship). This station is equipped with a television monitor, control stick, and other controls and displays necessary to maneuver the RPV through a specified course. The RPV, containing a television camera mounted in its nose, relays an image of the terrain to be displayed on the television monitor in the control station. Thus, the visual scene displayed to the operator represents the scene viewed by the camera. The task of the operator is to use the controls and displays to "fly" the RPV in much the same way he would fly a conventional aircraft.

The scenario is complicated by several factors. First, the visual inputs to the operator from the RPV are independent of the motion inputs from the control station. Thus, the operator will experience motion cues that are uncorrelated with the visual inputs received from the RPV. Second, while traditional pilot training programs operate on the philosophy that proprioceptive cues provided by the motion of the aircraft should be disregarded, research has shown that these cues are compelling, not easily ignored, and may improve performance when used in training simulators (see, for example, Borlace, 1967; Cohen, 1970; Douvillier, Turner, McLean, & Heinle, 1960; Fedderson, 1961; Huddleston & Rolfe, 1971; Rathert, Creer, & Douvillier, 1959; Ruocco, Vitale, & Benfari, 1965). The task simulated in the experiment presented here, however, required that the RPV operator disregard sensations of motion in order to maintain adequate performance. Under conditions of visual -proprioceptive conflict (as when the mother ship and/or the RPV are in turbulence) the stereotypic responses of pilots to correct angular accelerations will be inappropriate.

2. From page 7 (PDF page 10):

Visual system. The visual system consisted of a three-dimensional terrain model (a modified SMK-23 Visual Simulator, The Singer Company), television camera and optical probe, and three monochromatic television monitors. The terrain model provided "real-world ground cues for visual tracking over the surface. The real-world to terrain model scale was 3,000:1 and represented a six by twelve-mile (9.65 by 19.3 km) area. The model was mounted on an endless belt that was servo-driven to represent the continuous changes in scene as the simulated RPV traveled along north-south directions. A television camera viewed the terrain model through an optical probe that contained a servoed mechanical assembly to permit the introductions of heading, roll, and pitch. Both the camera and probe were mounted on a servo-driven carriage system that moved across the terrain model to simulate movement of the RPV along east-west directions and in and out to simulate altitude changes.

The SMK-23 was also used in The Lunar Roving Vehicle (LRV) simulator [{Ref. 15}](#). This shows what an SMK-23 looks like.

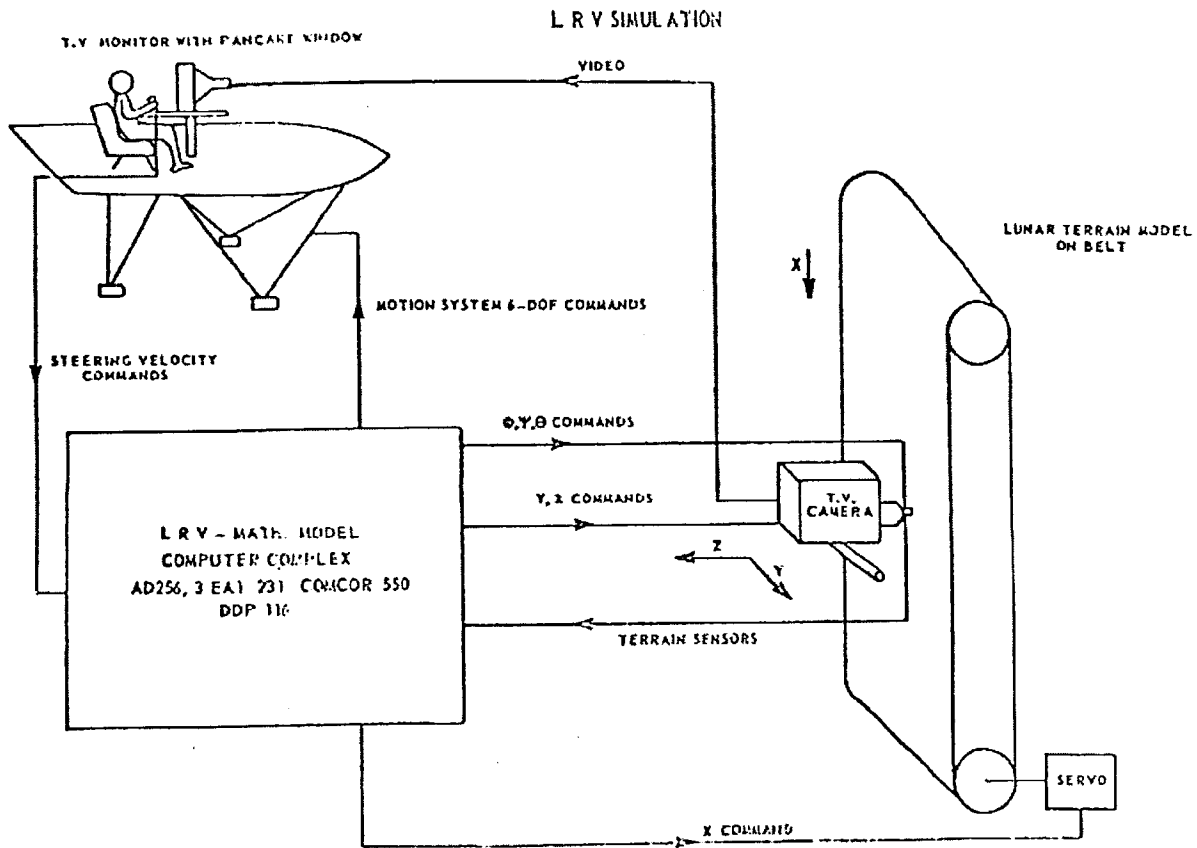

The SMK-23 used a television camera with an optical probe to fly over the terrain model contained on a servo-driven endless belt.

If Reed had had *synthetic vision* why would he have used the SMK-23 mechanical contraption?

The only link between Reed and HiMAT is that the HiMAT aircraft could be landed by either a ground-based pilot or an airborne controller (the backseat chase pilot in the TF-104G aircraft). [{Ref 13 – Evans & Schilling, PDF page 9}](#)

Actual.- The backup control system (BCS) is the second of the two independent flight control systems required for the Hi MAT program. The BCS control law is resident in one of the two onboard digital computers. The BCS is a full-authority, three-axis, multirate digital controller with stability augmentation functions and mode command functions (ref. 4). Each of seven modes is semiautomatic with the pilot providing direction by way of discrete command inputs. The BCS commands elevons for pitch and roll control and rudders for yaw control, and has an autothrottle for speed modulation.

The BCS was designed to provide well-controlled dynamics throughout the flight envelope, to have the ability to recover from extreme attitudes, and to bring the vehicle to a selected site and effect a successful landing by either a ground-based pilot or an airborne controller (the backseat chase pilot in the TF-104G aircraft). It was designed to provide these features for an unstable vehicle configuration of no more than 10-percent aft mean aerodynamic chord center-of-gravity location. The original HiMAT BCS was developed by Teledyne Ryan Aeronautical for the onboard microprocessor computer, and was programmed entirely in Intel 8080 assembly language.

While HiMAT might have used the results of the Reed report to select the airborne controller (the backseat chase pilot in the TF-104G aircraft) Reed did not use synthetic vision and neither did HiMAT.

Simulators

The AUVSI Authors describe several flight simulators, such as the RC AeroChopper by Ambrosia Microcomputer Products [Paragraphs 15 and 16] and Bruce Artwick's "Flight Simulator" for the Apple II, which ultimately became Microsoft Flight Simulator. [Paragraph 5]

RC AeroChopper was developed by David R. Stern at Ambrosia Microcomputer Products. The following is from an email correspondence with Mr. Stern:

Question 1: Did AeroChopper use a 3D terrain database?

Mr. Stern: I guess it did, although the ground was a plane with 3D objects (and a 2D runway) scattered around (trees, pylon, towers with crossbar to fly under).

Question 2: If so, did it represent real terrestrial terrain?

Mr. Stern: No.

Question 3: Did AeroChopper do real 3D?

Mr. Stern: Yes. All the objects including the aircraft were described by a list of points, a list of point pairs for lines and a list of which points were in each polygon, each point had an x,y and z component. The original version was started in 1984, shown at the first R/C show (I think in Storm Lake Iowa) in the summer of 1986, had only vector graphics. About 1990 I changed to filled polygons. The aircraft was rotated (pitch, yaw and roll) slightly each frame with respect to the fixed coordinate system. Then the aircraft and all background objects were rotated and scaled depending on the relative position of the "camera".

The view on the screen was initially from a fixed point about eye level for a standing R/C pilot. The "camera" rotated to keep the aircraft on the screen. In the late 80s, I added two different viewpoint options ("camera" flying near the aircraft) . One mode was just behind the aircraft, looking in the direction the aircraft was pointed. The second camera mode followed the aircraft to keep it from getting too far away but slowed and stopped as the aircraft got closer. You can often see the ground objects from the air in these modes.

I developed the first version on the Atari 520 ST computer in 68000 assembly language. Then I developed an Amiga version and then a Macintosh version. In about 1991, I developed an 80286 version for a DOS machine. (The latest version requires a Windows 98 or older machine with an RS232 port and runs under DOS)

RC AeroChopper was a significant achievement for the home computers available at the time and was a highly regarded simulator {Ref. 17} but:

1. It did not use a digital elevation database; "... the ground was a plane with 3D objects (and a 2D runway) scattered around (trees, pylon, towers with crossbar to fly under)," and thus, did not represent real terrestrial terrain.

2. It did not provide a computer-generated image of the external scene topography from the perspective of the flight deck that is derived from aircraft attitude, high-precision navigation solution, and database of terrain, obstacles and relevant cultural features.

It was not synthetic vision. It was a simulator.

Now, let's discuss Microsoft Flight Simulator *{Ref. 18}*:

Flight Simulator 5.1 was released in 1995. Microsoft Flight Simulator did not start using 3D terrain until Flight Simulator 2000 Pro, released in late 1999.

From *Ref. 19*:

GRAPHICS

We now have another complete globe to fly around. With the new mesh style scenery we have real elevation points that make the surrounding terrain rise and fall like the real earth. We have no more flat areas that just pop up into place at the last minute during a landing approach!

Even then, it is not clear if the terrain database represents real terrain or is made up.

The article mentions the new GPS feature:

737 Panel

The 737-400 panel is very nicely done. Simple, yet effective. This is where FS2000 is not much different than FS98. However, the overall clarity, coloring, detailing and some new systems make it much better. We now have nice popups for the throttle quadrant, radio stack, compass and best of all the new GPS.

The GPS is part of the simulated 737 control panel. There is no suggestion that a physical GPS unit can be connected to the program.

A simulator is not synthetic vision. A simulator might do a good job simulating synthetic vision. It might even use a Digital Terrain Elevation Database representing real terrestrial terrain, but that does not make it synthetic vision. It is a simulator. If it does not control a physical aircraft it is not synthetic vision.

When Did NASA Start Working on Synthetic Vision?

From *Ref 20*:

NEWS RELEASE

May 28, 1999

Synthetic Vision Could Help General Aviation Pilots Steer Clear of Fatalities

Hampton, Virginia -- Research Triangle Institute and six companies are teaming up to develop revolutionary new general aviation cockpit displays to give pilots clear views of their surroundings in bad weather and darkness.

The RTI Team includes Flight International, Inc., Newport News, Virginia. (a GA aircraft user) and Archangel Systems, Inc., Auburn, Alabama, who are committed to early commercialization and will make significant cost share contributions. The starting point for the new system is Archangel's TSO'd and STC'd Cockpit Display System.

RTI also has teamed with Seagull Technology, Inc., Los Gatos, California (a GPS and attitude/heading reference system technology firm), Crew Systems, Inc., San Marcos, Texas, (a designer of low-cost head up displays), and Dubbs & Severino, Inc., Irvine, California (an award-winning terrain database design company). In addition, FLIR Systems, Inc., Portland, Oregon (an infrared instrument manufacturer) has agreed to evaluate the costs and benefits of existing weather penetrating sensor technology.

Limited visibility is the greatest factor in most fatal aircraft accidents, according to the Aviation Safety Program at NASA's Langley Research Center in Hampton, VA. The RTI team is among six selected by NASA to develop different applications of Synthetic Vision.

The RTI team will design, develop, and certify a Synthetic Vision system for general aviation aircraft. The purpose is to reduce or eliminate controlled flight into terrain caused by visibility-induced human error.

Synthetic Vision is a display system that will offer pilots an electronic picture of what's outside their windows, no matter the weather or time of day. The system combines Global Positioning Satellite signals with terrain databases and graphical displays to draw three-dimensional moving scenes that will show pilots exactly what's outside.

The NASA Aviation Safety Program envisions a system that incorporates multiple sources of data into cockpit displays. The displays would show hazardous terrain, air traffic, landing and approach patterns, runway surfaces and other obstacles that could affect an aircraft's flight.

The NASA Aviation Safety Program is a partnership with the FAA, aircraft manufacturers, airlines and the Department of Defense. This partnership supports the national goal announced by President Clinton to reduce the fatal aircraft accident rate by 80 percent in 10 years and by 90 percent over 25 years.

Research Triangle Institute is an independent, not-for-profit organization that conducts R&D and provides technical services to industry and government. With a staff of more than 1,600 people, RTI is active in aerospace and many other fields of applied technology. RTI was created in 1958 as the centerpiece of North Carolina's Research Triangle Park, where its headquarters are located. RTI's Aerospace Technology Center in Hampton, Virginia, will carry out the Synthetic Vision project.

In a separate press release dated May 13, 1999 NASA announced {from Ref. 21}:

Industry teams submitted 27 proposals in four categories: commercial transports and business jets, general aviation aircraft, database development and enabling technologies. NASA and researchers from the Federal Aviation Administration and Department of Defense evaluated the proposals' technical merit, cost and feasibility.

NASA has committed \$5.2 million that will be matched by \$5.5 million in industry funds to advance Synthetic Vision projects over the next 18 months. More money is expected to be designated later to accelerate commercialization and make some systems available within four to six years.

Among the team leaders selected for the first phase of the program are: Rockwell Collins, Inc., Cedar Rapids, IA; AvroTec, Inc., Portland, OR; Research Triangle Institute, Research Triangle Park, NC; Jeppesen-Sanderson, Inc., Englewood, CO; the Avionics Engineering Center of Ohio University, Athens, OH; and Rannoch Corporation, Alexandria, VA.

Rockwell Collins, Inc. will receive funds to develop synthetic vision for airliners and business jets. The AvroTec, Inc. and Research Triangle Institute groups will use their awards to create technologies for a general-aviation synthetic vision system. A team led by Jeppesen-Sanderson, Inc. will receive funds to develop terrain database requirements and system approaches. The Avionics Engineering Center of Ohio University and Rannoch Corporation will use their awards to design specific component technologies for Synthetic Vision.

When did NASA start working on Synthetic Vision?

The answer is: 1999.

When did NASA first use synthetic vision to control a UAV?

It was in the X-38 project.

From Ref 22: "Virtual Cockpit Window" for a Windowless Aerospacecraft

Wednesday, January 01 2003

A software system processes navigational and sensory information in real time to generate a three-dimensional-appearing image of the external environment for viewing by crewmembers of a windowless aerospacecraft. The design of the particular aerospacecraft (the X-38) is such

that the addition of a real transparent cockpit window to the airframe would have resulted in unacceptably large increases in weight and cost.

When exerting manual control, an aircrew needs to see terrain, obstructions, and other features around the aircraft in order to land safely. The X-38 is capable of automated landing, but even when this capability is utilized, the crew still needs to view the external environment: From the very beginning of the United States space program, crews have expressed profound dislike for windowless vehicles. The well-being of an aircrew is considerably promoted by a three-dimensional view of terrain and obstructions. The present software system was developed to satisfy the need for such a view. In conjunction with a computer and display equipment that weigh less than would a real transparent window, this software system thus provides a "virtual cockpit window."

The key problem in the development of this software system was to create a realistic three-dimensional perspective view that is updated in real time. The problem was solved by building upon a pre-existing commercial program — LandForm C3 — that combines the speed of flight-simulator software with the power of geographic-information-system software to generate real-time, three-dimensional-appearing displays of terrain and other features of flight environments. In the development of the present software, the pre-existing program was modified to enable it to utilize real-time information on the position and attitude of the aerospacecraft to generate a view of the external world as it would appear to a person looking out through a window in the aerospacecraft. The development included innovations in realistic horizon-limit modeling, three-dimensional stereographic display, and interfaces for utilization of data from inertial-navigation devices, Global Positioning System receivers, and laser rangefinders. Map and satellite imagery from the National Imagery and Mapping Agency can also be incorporated into displays.

The Press Release from Rapid Imaging Software, Inc., which did the synthetic vision work for the X-38, states {[Ref. 23](#)}

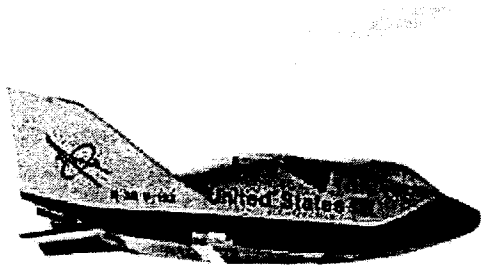

On December 13th, 2001, Astronaut Ken Ham successfully flew the X-38 from a remote cockpit using LandForm VisualFlight as his primary situation awareness display in a flight test at Edwards Air Force Base, California. This simulates conditions of a real flight for the windowless spacecraft, which will eventually become NASA's Crew Return Vehicle for the ISS. We believe that this is the first test of a hybrid synthetic vision system which combines nose camera video with a LandForm synthetic vision display. Described by astronauts as "the best seat in the house", the system will ultimately make space travel safer by providing situation awareness during the landing phase of flight.

Other References cited by the AUVSI Authors

"Pathway-in-the-Sky Contact Analog Piloting Display," Knox and Leavitt, 1977

In the article the AUVSI Authors state in Paragraph 7:

In 1977, NASA researcher Charles Knox published "Pathway-in-the-Sky Contact Analog Piloting Display," which included a complete design for a synthetic vision system. It featured a computer that projected a 3D view of the terrain given an aircraft's position and orientation. This out-the-window perspective view was displayed on a CRT type display. Such displays were called "Pictorial Format" avionics systems, but we recognize them as containing all of the essential elements of a modern synthetic vision display.

The pictures that will be reproduced shortly are from the Knox report (Charles E. Knox and John Leavitt). I have placed them with the descriptions from Knox pages 3-4. The complete Knox report is Ref. 24.

Everything comes together in Knox Figure 4, which shows the Airplane track-angle pointer and scale, the Airplane symbol with shadow superimposed, the Flight-path-angle scale, the Flight-path prediction vector, the Earth horizon, the Roll pointer, the Airplane altitude deviation from path, the Airplane flight-angle bars, the Programmed path-angle indicator, the Potential flight-path-angle box, and the Programmed flight path.

The Programmed flight-path consists of two three-dimensional lines showing the predicted flight path of the airplane. Knox and Leavitt's work is significant but there is no terrain, there is no digital elevation database. There is no synthetic vision.

From Knox **Description of Path-in-the-Sky Contact Analog Piloting Display** {Ref. 24}:

Display Symbolology

The format of the PITS contact analog display shows airplane attitude information in the form of bank angle and pitch changes. Airplane performance information is shown in the form of airplane flight-path angle and flight-path acceleration (which may be used as thrust- or energy-management control). Both vertical and lateral path deviations during a tracking task are shown in pictorial form.

Path-tracking situation information is shown through a combination of an airplane symbol, a vertical projection of the airplane symbol with an extended center line drawn at the altitude of the path, a flight-path predictor, and a drawing of the programmed path (fig. 1). These four pieces of symbolology are drawn in a perspective display format as if the observer's eye were located behind and above the airplane.

The airplane symbol is a tetrahedron with a smaller tetrahedron at the tail to visually enhance pitch changes. The airplane's true position with respect to the path is at the symbol's apex. The symbol rolls and pitches about its apex in accord with the real airplane's attitude.

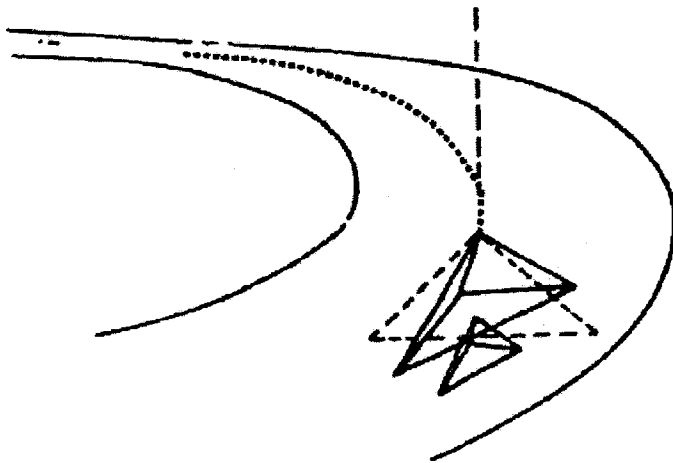
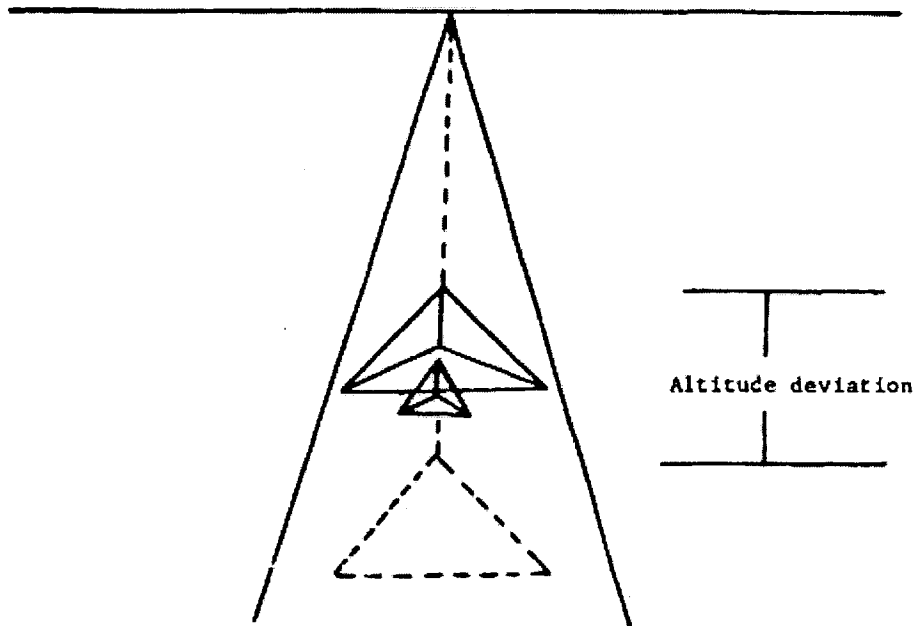
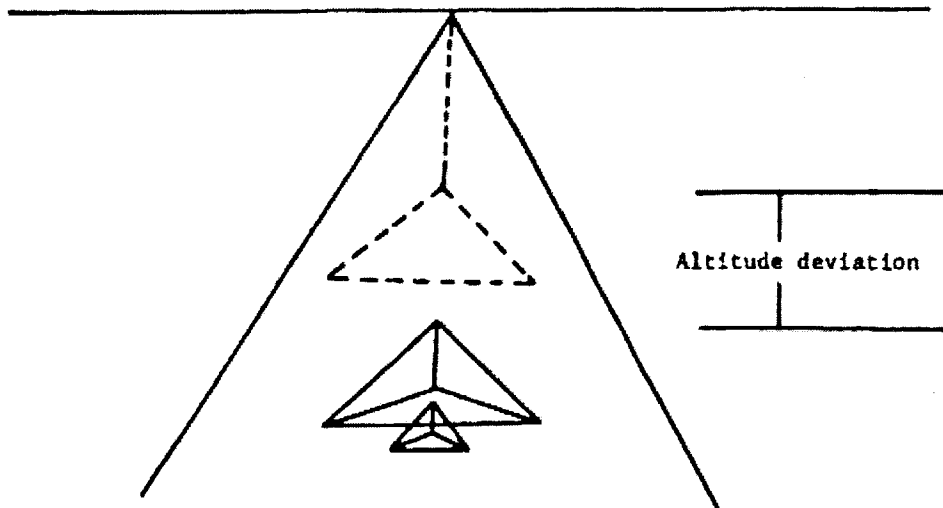

Figure 1.- Path, shadow, flight-path predictor, and airplane symbology.

Altitude deviations from the programmed path are indicated to the pilot pictorially by a vertical projection of the airplane symbol. The projection, drawn with dashed lines, may be thought of as a shadow; as shown in figure 2, it remains directly above or below the airplane at the altitude of the path. If the airplane is above the programmed path, the shadow appears to be below the airplane symbol. If the airplane is below the programmed path, the shadow appears to be above the airplane symbol.



(a) Above path.



(b) Below path.

Figure 2.- Airplane symbol and shadow interactions during altitude deviations.

Since the shadow is always drawn directly above or below the airplane symbol, the pilot may readily identify lateral tracking deviations when they are combined with a vertical tracking error. Figure 3 shows the perspective view of the shadow, the airplane symbol, and the path when the airplane is above and to the left of the path.

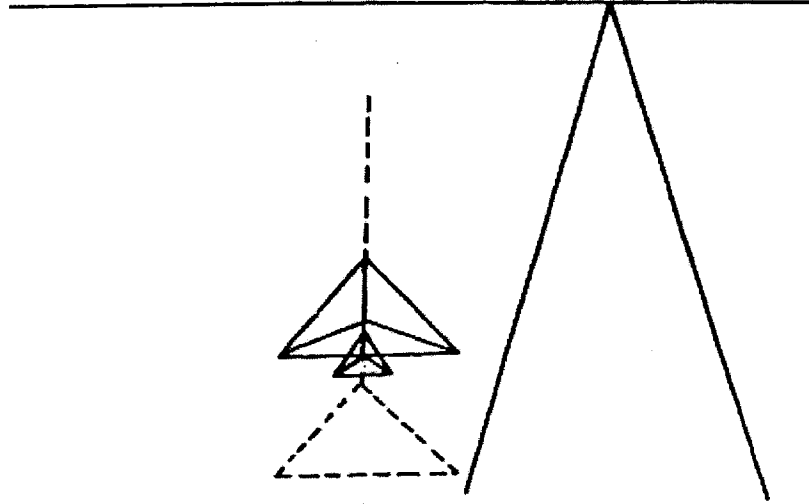

Figure 3.- Airplane above and to left of path.

Altitude deviations from the programmed path are also shown to the pilot in numerical form in a box in the upper right-hand corner of the display (fig. 4). The pilot is expected to use this information when the path and shadow are out of the display field of view, such as could occur during initial path captures.

A flight-path prediction vector (fig. 4) in the horizontal plane is attached to the shadow. The prediction vector, indicated by a dashed line, shows the airplane's predicted path for the next 10 sec based on the airplane's present bank angle and ground speed. An extended shadow center line drawn from the apex of the shadow in the direction of the present track angle, is also shown to aid the pilot with the lateral tracking task.

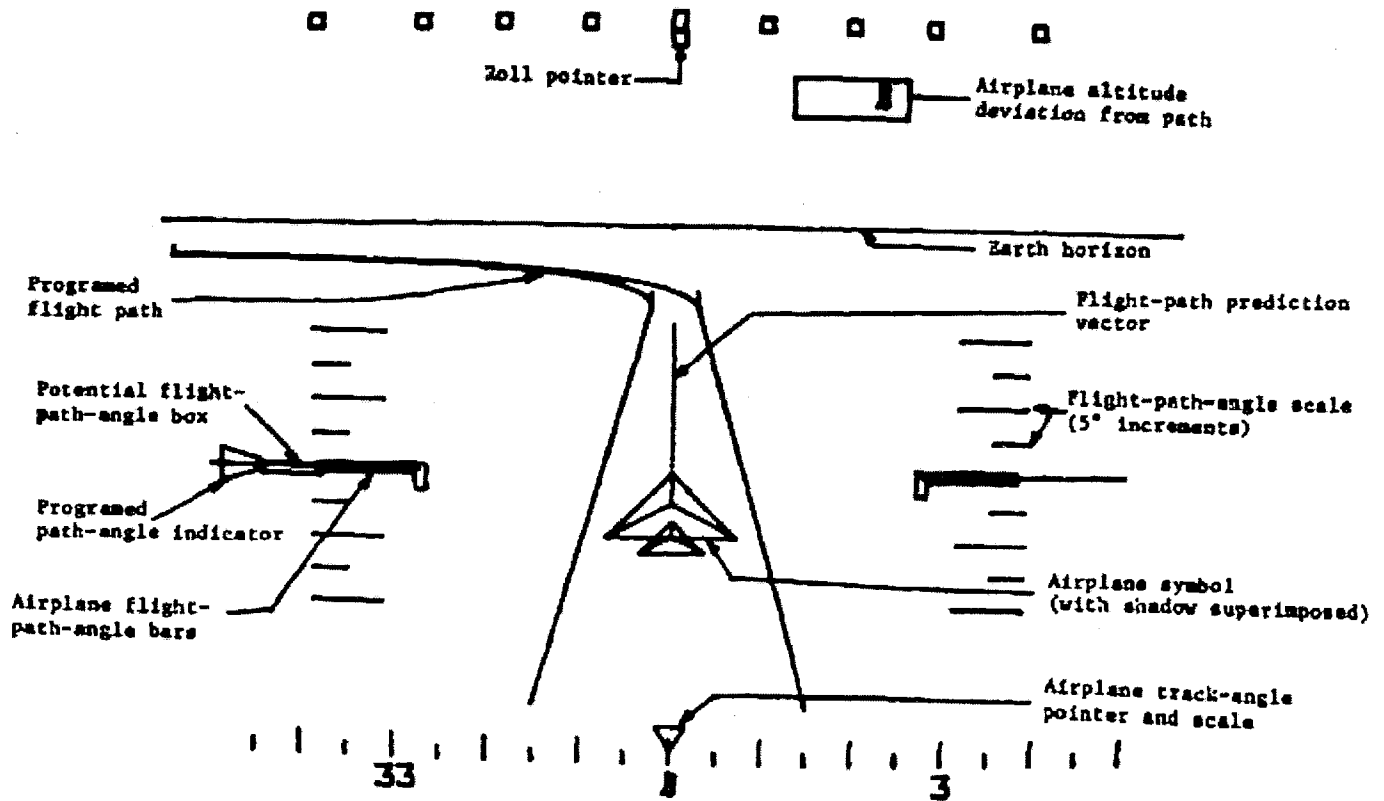

Figure 4.- The PITS contact analog display symbology.

Figure 5 shows the flight-path prediction vector and the present track indicator with the airplane in a left bank of 13° .

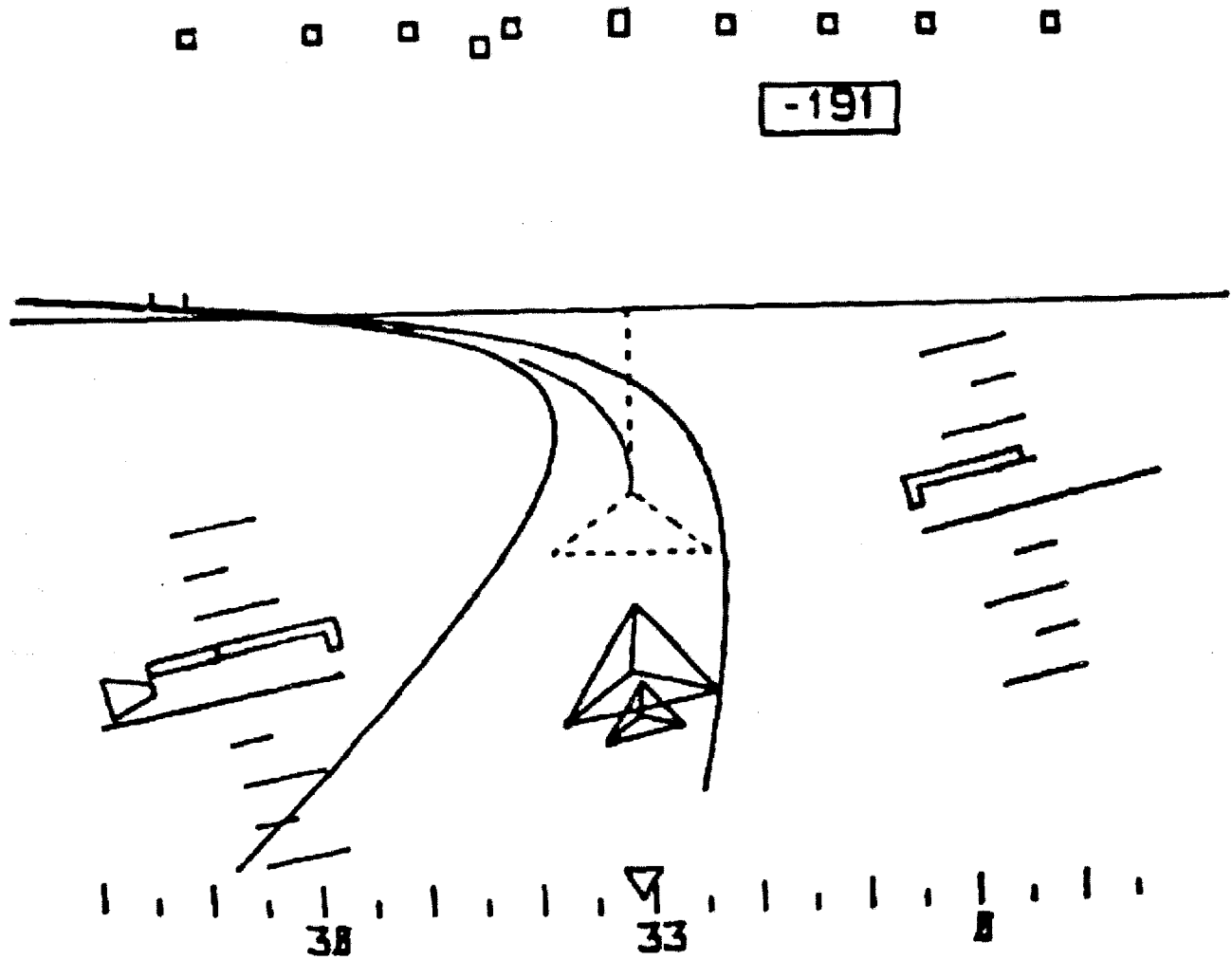

Figure 5.- The PITS display concept showing airplane below path and climbing in a left bank of 13° .

"The Electronic Terrain Map: A New Avionics Integrator", Small, D.M., 1981

In the article the AUVSI Authors state in Paragraph 8:

In 1979, the U.S. Air Force completed its "Airborne Electronic Terrain Map Applications Study" and in 1981 published "The Electronic Terrain Map: A New Avionics Integrator" describing how a computerized terrain database could be displayed as an out-the-window 3D view allowing the pilot to "see" even at night and in other limited visibility situations.

No, Small did not describe "how a computerized terrain database could be displayed as an out-the-window 3D view allowing the pilot to 'see' even at night and in other limited visibility situations."

The Small report discusses the concept of a digital Electronic Terrain Map (ETM) and proposes that it be used for:

1. Navigation;
2. Terrain Following/Terrain Avoidance (TF/TA);
3. Threat avoidance, analysis, warning, and display;
4. Terrain Masking;
5. Weapon delivery;
6. Route planning.

He does say, "An electronic map subsystem can generate perspective scenes, which are essentially computer generated images of the surrounding area, and an electronic map should be much easier to interpret," but:

1. The statement must be understood according to the meaning it would have had at the time the article was written (circa 1981); and
2. Wishing for a desired result is not the same as teaching how to do it.

This is what the Small report [Ref. 25] is about:

From the section INTRODUCTION:

INTRODUCTION

Currently, the Air Force has in the inventory paper and film map systems, which were developed to support the high and level flight environment. These maps were an effective means of tapping the vast files of information stored in the Defense Mapping Agency (DMA) data base, when the crew had time to study and interpret them (in fact, much of their value was actually obtained from pre-flight mission preparations). Interviews with pilots indicate that paper maps are less useful for low altitude flights. Film maps with CRT annotation are somewhat better, but still have a fundamental limitation in that it takes an operator to access any information. That is, it is not possible to transfer information directly from the data base to any other avionics system when it is stored on paper or film maps in what is essentially an analog form.

The map reading process is a demanding task that can be simplified by using a digital map subsystem which accesses the information needed and presents it in a form which can be easily interpreted. At low altitude, and with a line of sight limited to the next ridge line, it's very difficult to interpret standard paper maps, which are presented as a vertical projection of a large

area. An electronic map subsystem can generate perspective scenes, which are essentially computer generated images of the surrounding area, and an electronic map should be much easier to interpret. In addition, essential information from the map data base can be placed on the pilots Head Up Display, reducing the need for head down operations.

Paper maps are clumsy to use, whether you are flying an aircraft or driving a car. An electronic map, if properly done, would make using a map easier.

However, whether the map is electronic or on paper, you still have to know where you are. Small has not addressed that issue in this section.

The issue of what Small might mean by "perspective scenes" will be addressed later.

From the section FUTURE AIRCRAFT SYSTEM:

FUTURE AIRCRAFT SYSTEM

The purpose of adding an ETM subsystem to a future avionics suite is to provide map data and displays that can be interfaced with other subsystems to improve the performance of the terrain following/terrain avoidance (TF/TA), threat avoidance and navigation avionics subsystems. The requirement for the simultaneous exchange of processed map data by three or four avionics subsystems will be the most difficult objective and important feature of the ETM. Development and incorporation of the advanced ETM concepts and technologies will be required to augment future threat avoidance, navigation, TF/TA, and weapon delivery avionics subsystems. Applications/examples of using these ETM concepts and/or technologies and the utilization of an ETM subsystem as a source of information follows.

TF/TA

The first example will be the automatic TF/TA avionics subsystem. Our existing automatic TF subsystems operate using only active sensors as sources of terrain profile information (i.e. radar). This makes the subsystem totally dependent on the limitations of this single information source. In case of radar, range is limited to line of sight. Absolutely no information is available beyond line of sight. This forces the TF subsystem to provide unnecessarily large clearances over ridges to avoid the following peak which may or may not be imminent. Further, the TF subsystem must radiate on an almost continuous basis to provide a continuous terrain profile. Consequently detection and jamming are TF subsystem vulnerabilities. A digital terrain map could provide a second source of information to the TF flight command processing subsystem and the use of the map could serve as a backup in case of radar failures or jamming. The ETM could provide information concerning beyond line of sight conditions, enlarge the total field of view scanned for turning, and avoid the reduction of the duty cycle of the radar emission. In fact, this ability to scan the terrain to the side without turning and looking beyond the line of sight makes it possible for the first time to consider true automation of the TA function. Because of limitations in the existing DMA data base, the approach should be cautious and an active sensor will be needed to make absolute clearance measurements. None the less, the application of stored data, to the TF/TA problem can potentially have tremendous impact on Air Force capabilities in the low altitude flight mission.

1. Existing Terrain Following systems use active radar to profile the terrain. The radar is line-of-sight, so it cannot see farther terrain hidden by closer terrain.
2. An Electronic Terrain Map would allow you to determine what is over the next ridge. However, "Because of limitations in the existing DMA data base, the approach should be cautious and an active sensor will be needed to make absolute clearance measurements.

You still need to know where you are so you can locate your position on the map.

THREAT AVOIDANCE

The second example will be the threat avoidance avionics subsystem. The whole purpose of low altitude missions is to reduce the probability of detection and attrition. If the threat avoidance problem is solved without regard to the location and lethal range of threats, the resultant path may place the aircraft in greater jeopardy than before. Terrain masking and launch dynamics limitations must be exploited to the fullest. Careful selection of the aircraft's routes to the target may be done by the crew or automatically. In either case, a digital map is required to provide the terrain information and the position of the threats identified by the avionics system. Pre-mission planning can provide a starting point for this analysis, but the dynamics of the threat assessment makes it essential that the crew be able to redefine the mission as new information is received from command and control functions or via the aircraft's own suite of threat defense sensors.

1. If you have a good terrain map you can use the terrain to hide your aircraft from those whom you do not want to know where you are or if you are even in the area.
2. If your terrain map shows you where the threats are, don't go there.

You still have to know your map position.

NAVIGATION

The third example will be the navigation avionics subsystem. With the addition of a correlator to the avionic suite and using the on-board sensors together with the ETM, navigation can be accomplished. Also, by displaying the ridge lines derived from stored terrain data on the head up display, passive navigation is possible. Hence, the ETM could also improve the utilization of the navigation subsystem.

Small does not say what he means by a "correlator" or which onboard sensors he would use them with.

There can be several types of "correlators."

1. You can visually look out your aircraft window at the terrain (mountains, lakes, rivers) and cultural features (towers, highways) and then look at a map and try to find them. Then you figure out where you would be on the map to see what you are seeing. The map can be paper or electronic. An example of a paper map converted to digital format is in [Ref 26](#). This is part of the Washington Sectional Aeronautical Chart, Scale 1:500,000 55th Edition, published March 3, 1994 by U.S. Department of Commerce National Oceanic and Atmospheric Administration National Ocean Service. [Click Here for map PDF](#). If

you are not familiar with the symbology used in paper sectional maps here is the Washington Legend.

If you use the Zoom and Pan features of Acrobat you will see the advantages of an electronic version of a paper map (i.e., a digital map).

2. You can use a computer to do the correlation, such as the method taught by Horn and Bachman in **Using Synthetic Images to Register Real Images with Surface Models.** *{Ref. 27}*

Abstract: A number of image analysis tasks can benefit from registration of the image with a model of the surface being imaged. Automatic navigation using visible light or radar images requires exact alignment of such images with digital terrain models. In addition, automatic classification of terrain, using satellite imagery, requires such alignment to deal correctly with the effects of varying sun angle and surface slope. Even inspection techniques for certain industrial parts may be improved by this means.

Small has not mentioned *Terrain Referenced Navigation*. In Terrain Referenced Navigation a Radar or Lidar is used to take a few elevation measurements of the terrain. These measurements are matched to the terrain in a digital terrain elevation database.

An early example of Terrain Referenced Navigation is U.S. Patent 3,328,795 **Fixtaking Means and Method** issued June 27, 1967 to Hallmark. *{Ref 28}* From Column 2, lines 18-53:

Previously proposed fixtaking and navigational systems have sought to utilize terrain elevation data, and they have been based upon the analog comparison of sample data which are the continuous, analog representation of continuous variations in terrain elevations, with similar data contained in contour maps employed as such. At least some of the sample and known data hence have always been graphically or photographically displayed on actual sheets of paper, rectangles of photographic film, etc., and the values represented thereby have been shown as physically measurable along at least two axes. Because of the nature of the data employed, cumbersome and unwieldy equipments for photographic development, superposition of map over map, orthogonal adjustments of one set of data relative to another, etc. have been unavoidable sources of added weight, complexity, error, and malfunction.

The present invention does not employ continuously recorded, analog data, but has as one of its bases the use of quantized terrain altitude information taken at discrete points. A numerical comparison of sample and prerecorded data is performed at high speed, and with results predictable and repeatable for the same inputs, by a digital computer. Since the digital computer and associated components are relatively unaffected by noise, vibrations, nuclear radiation, etc., no equipment is required for performing two-dimensional data comparisons, and no feedback or nulling circuitry is needed for determining the point of best physical correlation of the sample with the pre-recorded data. As distinguished from systems utilizing analog information, the digital computer is free from the sources of error unavoidably present where analog comparisons are made and hence is not only more accurate but is able to tolerate relatively large errors in sample and known data values without compromising fixtaking accuracy.

TERCOM (Terrain Contour Matching) uses contour matching instead of elevations. **U.S. Patent 4,347,511 Precision navigation apparatus** issued August 31, 1982 to **Hofmann , et al.** *{Ref. 29}* mentions:

"Aviation Week & Space Technology", Feb. 25, 1974, page 50, ff, discloses the *Tercom* process. In the latter, barometric measuring devices and radio altimeters produce altitude profiles during specific time intervals of a flight over characteristic terrain. The one-dimensional differential profile between the barometric altitude and altitude above ground is compared with a two-dimensional reference profile. Here, the measured altitude profile is adjusted until the best correlation is achieved, so that the exact position of the aircraft results.

There are some problems with Terrain Referenced Navigation and Tercom:

1. They are not reliable if the terrain changes after the Digital Terrain Map is made. Terrain can change seasonally due to snow accumulations or permanently due to vegetation growth (trees) or new buildings (technically, a cultural feature).
2. They do not work over large flat terrain. {See Ref. 30}
3. They do not work over bodies of water.

Although Terrain Referenced Navigation and Tercom systems that use Radar or Lidar still send out signals that can be detected, the signals are far less detectable than the signals used in Small's description of TF/TA systems. Small's TF/TA system uses a radar to scan the terrain, which is why it cannot see beyond the next ridge.

Small's omission of Terrain Referenced Navigation and Tercom is puzzling.

Small gives a choice between Radar-scanned terrain and finding your location on a map using an undefined method of adding a correlator to the avionics suite and using the on-board sensors together with the Electronic Terrain Map (ETM).

What did Small mean when he said, "An electronic map subsystem can generate perspective scenes, which are essentially computer generated images of the surrounding area, and an electronic map should be much easier to interpret?"

In the 1980s (and well into the 1990s) the conventional wisdom was that Real 3D graphics was too computationally intensive to do in real time without large and very expensive hardware.

Honeywell was the leader in avionics. Harris was probably a close second. They both spent the 1980s and 1990s competing with each other to see who could do the best fake 3D.

For example, U.S. Patent 4,660,157 **Real time video perspective digital map display method** issued April 21, 1987 to Beckwith, et al. {Ref. 31}

Instead of mathematically rotating the points from the database the '157 Patent accounts for the aircraft's heading by controlling the way the data is read out from the scene memory. Different heading angles result in the data being read from a different sequence of addresses.

From Column 3, lines 21 - 38:

The addresses of the elevation data read out of the scene memory representing points in the two-dimensional scene of the terrain are then transformed to relocate the points to positions where they would appear in a perspective scene of the terrain. Thus, each point in the two-dimensional

scene is transformed to its new location in the perspective scene to be displayed on the viewing screen, and in the process, the data is automatically oriented with a heading-up disposition. The transformed points are then stored in a speed buffer for further processing by sun angle and line writing logic prior to being stored in a display memory from which data is read out to the display screen. Since data in the display memory represents one-to-one data to be displayed on the CRT, this data will be referred to as pixels (picture elements) in terms of its storage in the display memory for transfer to the CRT display.

The '157 patent accounts for the roll attitude of the aircraft by mathematically rotating the screen data after it is projected. From Column 12, lines 42 - 47:

The points which are output by the perspective transform circuit 110 are supplied to a screen rotation circuit 120 which serves to rotate the display data in accordance with the roll of the aircraft so that the display will accurately depict the view as it would appear, if visible, through the window of the aircraft.

Beckwith displays only points.

Fake 3D + Only Points does not qualify as what is now considered synthetic vision.

There is Honeywell's U.S. Patent 5,179,638 **Method and apparatus for generating a texture mapped perspective view** issued January 12, 1993 to Dawson, et al. (Ref. 32)

It even has the word "perspective" in the title, but the perspective it produces is a trapezoidal perspective, not a real 3D projected perspective.

Dawson '638 incorporates by reference a number of other patents and patent applications, and determining exactly what Dawson meant in '638 requires following a trail through these patents. The short version is that what Dawson means by "perspective" is contained in U.S. Patent 4,884,220 **Address Generation with Variable Scan Patterns** issued November 28, 1989 to Dawson (again), (Ref. 33) which is incorporated by reference by Dawson '638.

After discussing the shortcomings of prior art, Dawson '220 says (Column 2, line 56 through Column 3, line 2):

This invention differs from the prior methods of perspective view generation in that a trapezoidal scan pattern is used instead of the radial scan method. The trapezoidal pattern is generated by an orthographic projection of the truncated view volume onto the cache memory (terrain data). The radial scan concept is retained, but used for an intervisibility overlay instead of the perspective view generation. The radial scan is enhanced to include a full 360 degree arc with programmable attributes. The rectangular pattern retains the parallel scan methodology for plan view map generation. Both a nearest neighbor and a full bilinear interpolation method of scan address generation are implemented.

And now we know what Dawson means by "perspective."

A real 3D perspective is a 3D projection.

Anything else is Fake 3D.

If you think Fake 3D is just as good as Real 3D then the next time someone owes you money tell them that it's ok to pay you in fake dollars.

There is also the matter that Small is only wishing for a desired result. Wishing for a desired result is not the same as teaching how to do it.

Not only did Small not teach it, he was not clear in saying what he was wishing for.

VCASS: An Approach to Visual Simulation, Kocian, D., 1977

In the article the AUVSI Authors state in Paragraph 6:

This emergence of computer flight simulation in the 1970s appears to have sparked a monumental amount of research. The U.S. Air Force began its Visually Coupled Airborne Systems Simulator (VCASS) program, with a particular eye toward future-generation fighter aircraft ("VCASS: An Approach to Visual Simulation," Kocian, D., 1977).

The Kocian report is available in Ref. 34.

Summary

Kocian is about using a Helmut Mounted Display (HMD) with a Head Position Sensing System to replace large expensive hemispherical display systems used in simulators. The simulator is used to develop the visual interface used by crew members to control advanced weapon systems. This visual interface can then be used in airborne operations.

During simulation a representative visual scene is generated by the graphics or sensor imagery generators but, from Paragraph 11 (emphasis added):

For an airborne VCASS capability, it is only necessary to install the VCS components along with a small airborne general purpose computer in a suitable aircraft and interface a representative programmable symbol generator to an on-board attitude reference system in order to synthesize either airborne or ground targets.

The airborne version does not synthesize a visual scene, so it is not synthetic vision.

Details

A Visually-Coupled System is one that visually couples the operator to the other system components through the use of a Helmut Mounted Display (HMD) and Helmut Position Sensor. From Paragraph 9:

The key components of VCASS will be VCS hardware which includes the HMS and HMD. These components are used to "visually-couple" the operator to the other system components he is using. AMRL has pioneered efforts in the research, development and testing of these hardware techniques.

A system using a Helmet Mounted Display with a Helmet Position Sensor is less expensive than the hemispherical projection systems being used and produces better results. Paragraph numbers have been added to the following paragraphs from Kocian.

[1] In recent years Air Force operational units have experienced a continuing trend downward in the number of flight hours in aircraft that can be provided to each individual pilot for training and maintaining proficiency. This comes at a time when aircraft systems are becoming ever more complex and sophisticated requiring comparatively more hours for training to maintain the same relative flying proficiency. With increasing costs for fuel and aircraft and the failure of DoD funding to keep pace with these costs, the trend is almost sure to continue. In adjusting to the realities of keeping overall experience at a satisfactory level and reducing costs, procurement of aircraft simulators has become a necessity.

[2] The rapid proliferation of simulators with no standard technical criteria as a guide has resulted in the evolution of several different design approaches. Most existing visual scene simulators utilize electro-optical devices which project video imagery (generated from a sensor scan of a terrain board or a computer generated imagery capability) onto a hemispherical dome or set of large adjacent CRT displays arranged in optical mosaics with the weapon, vehicle, and threat dynamics being provided by additional computer capabilities.

[3] These large fixed-base simulators suffer from the following drawbacks. The majority of the visual projection techniques used in these simulators do not incorporate infinity optics which provide collimated visual scenes to the operator. Those which do are large and expensive and incorporate large CRT displays. The luminance levels and resolution of these displays are usually low and do not represent true ambient conditions in the real environment. Additionally, hemispherical infinity optics are difficult to implement and this technique requires excessive computer capacity to generate imagery due to the need for refreshing an entire hemisphere instantaneously, regardless of where the crew member is looking. In this regard, existing computer capability is not used effectively to match the channel capacity of the human visual system. There are also generally no stereoscopic depth cues provided for outside-of-cockpit scenes. Another important drawback to these simulators is that the visual simulation is not transferrable to the actual flight environment, i.e., the ground-based system cannot be transferred to an actual aircraft to determine simulation validity. Finally, most existing techniques are very expensive and do not allow the flexibility of incorporating other display design factors such as different head-up display image formats, fields-of-view (FOV), representative cockpit visibilities, and optional control and display interfaces.

[4] A quite different approach to solving the visual presentation problems of aircraft simulators is to employ the use of visually coupled systems (VCS). For many years it has been the mission of the Aerospace Medical Research Laboratory to optimize the visual interface of crew members to advanced weapon systems. This mission has been primarily pursued in two areas: (1) the establishment of control/display engineering criteria; and (2) the prototyping of advanced concepts for control and display interface. An important part of fulfilling this mission has been the development of VCS components which includes head position sensing systems or helmet mounted sights (HMS), eye position sensing systems (EPS) and helmet mounted displays (HMD).

During simulation a representative visual scene is generated by the graphics or sensor imagery generators. From Paragraph 7:

A more detailed analysis of the problem has produced a set of characteristics which a more ideal aircraft simulator might possess. Of primary importance is that it should be a flexible visual scene simulation providing synthesized out-of-the-cockpit visual scenes and targets, a representative vehicle whose type can be altered, threat and weapon dynamics, flexibility of control and display configurations, and inputs from sensor or real world imagery. It should be portable if possible and provide alternatives for crew station display options including number and configuration. This simulator should also be useable in both simulated air-to-ground weapon delivery and air-to-air engagement scenarios. Finally, it should be possible to use the same system in ground fixed base and motion base simulators as well as in aircraft.

However, the airborne version does not synthesize the out-the-cockpit visual scene. It only displays the symbols used in its role as a weapons controller. That is why the airborne version only needs a small airborne general purpose computer. From Paragraph 11 (emphasis added):

For an airborne VCASS capability, it is only necessary to install the VCS components along with a small airborne general purpose computer in a suitable aircraft and interface a representative programmable symbol generator to an on-board attitude reference system in order to synthesize either airborne or ground targets. This approach has the ultimate flexibility of utilizing the same symbol set, threat dynamics, etc., in the air that were originally used in the ground simulation. In either case, the crew member will engage electronic targets (either air-to-air or air-to-ground) and launch electronic weapons. His performance in these tasks in turn will be recorded and assessed for performance or utilized as training aids for the crew member or operator.

The airborne version does not synthesize a visual scene, so it is not synthetic vision as the term is now used.

In addition, the Kocian report describes a work-in-progress. From Paragraph 19:

The design considerations involved in building a helmet-mounted display for the VCASS simulation present a more formidable and subjective set of problems whose solution is not entirely clear. It is certain that a larger display field-of-view is required but how large remains an unanswered question. The optical physics that are part of the display design imposed constraints which are difficult to resolve. Currently, an interim display possessing a 60 degree instantaneous field-of-view is planned for the VCASS; however, recent studies have shown that this may not be large enough especially when viewed with one eye. This leads naturally to biocular or binocular configurations. A whole host of human factors problems then becomes important including brightness disparity, display registration, and eye dominance. The decision whether or not to include color also becomes a major design decision not only because of the engineering development required but because user acceptance may weigh heavily on this factor.

(The question whether or not to use color was later settled. The answer was color.)

U.S. Patent 5,566,073 Pilot Aid Using A Synthetic Environment
issued October 15, 1996 to Margolin

This patent was not mentioned by the AUVSI Authors.

Abstract

A pilot aid using synthetic reality consists of a way to determine the aircraft's position and attitude such as by the global positioning system (GPS), a digital data base containing three-dimensional polygon data for terrain and manmade structures, a computer, and a display. The computer uses the aircraft's position and attitude to look up the terrain and manmade structure data in the data base and by using standard computer graphics methods creates a projected three-dimensional scene on a cockpit display. This presents the pilot with a synthesized view of the world regardless of the actual visibility. A second embodiment uses a head-mounted display with a head position sensor to provide the pilot with a synthesized view of the world that responds to where he or she is looking and which is not blocked by the cockpit or other aircraft structures. A third embodiment allows the pilot to preview the route ahead or to replay previous flights.

It teaches what is now known as synthetic vision in sufficient detail that it may be practiced by a *Person having Ordinary Skill In The Art* without undue experimentation. A Person having Ordinary Skill In The Art (POSITA) is a legal term that is often fought over during patent litigation.

This patent is a continuation of Application Ser. No. 08/274,394, filed Jul. 11, 1994, which is its filing priority date. The earliest known description of the invention is in Ref. 35.

For those unfamiliar with Patent Law, the Claims are the legal definition of the invention. The purpose of the Abstract is to provide search terms only.

See Ref. 36 for the patent. (I am the inventor named in the patent.)

U.S. Patent 5,904,724 Method and apparatus for remotely piloting an aircraft
issued May 18, 1999 to Margolin

This patent was also not mentioned by the AUVSI Authors.

Abstract

A method and apparatus that allows a remote aircraft to be controlled by a remotely located pilot who is presented with a synthesized three-dimensional projected view representing the environment around the remote aircraft. According to one aspect of the invention, a remote aircraft transmits its three-dimensional position and orientation to a remote pilot station. The remote pilot station applies this information to a digital database containing a three dimensional description of the environment around the remote aircraft to present the remote pilot with a three dimensional projected view of this environment. The remote pilot reacts to this view and interacts with the pilot controls, whose signals are transmitted back to the remote aircraft. In addition, the system compensates for the communications delay between the remote aircraft and the remote pilot station by controlling the sensitivity of the pilot controls.

It teaches the use of synthetic vision (as the term is currently used) for remotely piloting an aircraft. It teaches it in sufficient detail that it may be practiced by a Person having Ordinary Skill In The Art without undue experimentation.

This patent was filed January 19, 1996, which is its priority date.

For those unfamiliar with Patent Law, the Claims are the legal definition of the invention. The purpose of the Abstract is to provide search terms only.

See Ref. 37 for the patent. (I am the inventor named in the patent.)

U.S. Patent Application Publication 20080033604
System and Method For Safely Flying Unmanned Aerial Vehicles in Civilian Airspace

In the interests of full disclosure I have the following patent application pending: U.S. Patent Application Publication 20080033604 **System and Method For Safely Flying Unmanned Aerial Vehicles in Civilian Airspace.**

Abstract

A system and method for safely flying an unmanned aerial vehicle (UAV), unmanned combat aerial vehicle (UCAV), or remotely piloted vehicle (RPV) in civilian airspace uses a remotely located pilot to control the aircraft using a synthetic vision system during at least selected phases of the flight such as during take-offs and landings.

See Ref. 38 for the published patent application. (I am the inventor named in the application)

The Future of Synthetic Vision

This is what the AUVSI Authors have said about synthetic vision [Paragraph 2]:

More recently it has evolved away from being a piloting aid to a potentially powerful tool for sensor operators.

and [Paragraph 22]:

The recent availability of sophisticated UAS autopilots capable of autonomous flight control has fundamentally changed the paradigm of UAS operation, potentially reducing the usefulness of synthetic vision for supporting UAS piloting tasks. At the same time, research has demonstrated and quantified a substantial improvement in the efficiency of sensor operations through the use of synthetic vision sensor fusion technology. We expect this to continue to be an important technology for UAS operation.

While I have no doubt that synthetic vision is very useful to the sensor operator, the news that its use in piloting UAVs is on its way out came as a big surprise to me.

The AUVSI Authors have an ulterior motive in making the statements. Their real objective is to make people believe synthetic vision no longer has value in controlling Remotely Piloted Vehicles (aka UAVs) and that a Remotely Piloted Vehicle that is flown using an Autonomous control system is no longer a remotely piloted vehicle and therefore a sensor operator may use synthetic vision without infringing U.S. Patent 5,904,724. See Ref. 39 for the response Rapid Imaging Software's attorney sent to Optima Technology Group in 2006.

The statements made by the AUVSI Authors form a distinction without a difference unless there is a wall between the sensor operator and the pilot that results in the sensor operator having no influence on how or where the UAV is flown.

Consider the following scenarios:

1. The human sensor operator has synthetic vision; the human pilot does not. No communications is allowed between the human sensor operator and the human pilot lest the human sensor operator influence the human pilot where or how to fly the aircraft. Otherwise, it might be considered as contributing to piloting the aircraft. This results in a decidedly sub-optimal system.
2. The human sensor operator has synthetic vision; the aircraft is flown autonomously (a machine pilot). No communications is allowed between the human sensor operator and the machine pilot lest the human sensor operator influence the machine pilot where or how to fly the aircraft. Otherwise, it might be considered as contributing to piloting the aircraft. This also results in a decidedly sub-optimal system.

There are legal and political ramifications to this scenario.

Someone has to be responsible for the operation and safety of the flight. The FAA defines "Pilot in Command" as {Ref. 5}:

Pilot in command means the person who:

- (1) Has final authority and responsibility for the operation and safety of the flight;
- (2) Has been designated as pilot in command before or during the flight; and

(3) Holds the appropriate category, class, and type rating, if appropriate, for the conduct of the flight.

It is unlikely that FAA will allow this responsibility to be delegated to a machine anytime soon. That's where the political ramifications come in. A UAV (especially a completely autonomous UAV) that injures or kills civilians would ignite a political firestorm that would ground the entire UAV fleet.

Since there must be a human in the loop to be responsible for the operation and safety of the flight, that leaves a system where:

1. The human sensor operator has synthetic vision;
2. The pilot is a machine;
3. The operation and safety of the flight is held by a human (different from the sensor operator) who is designated the Pilot-in-Command;
4. No communications is allowed between the human sensor operator and the machine pilot or the human sensor operator and the human Pilot-in-Command lest the human sensor operator influence the machine pilot or the human Pilot-in-Command where or how to fly the aircraft. Otherwise, it might be considered as contributing to piloting the aircraft. This also results in a decidedly sub-optimal system.

Frankly, it is stupid to cripple the utility of a UAV system in order to avoid paying a small patent licensing fee. Besides, the '724 patent is for the use of synthetic vision in a Remotely Piloted Aircraft. It is not limited to the use of synthetic vision by the crew member designated as the Pilot.

An autonomous pilot would have to be really good.

Even after 100 years of aviation, pilots still encounter situations and problems that have not been seen before. The way they deal with new situations and problems is to use their experience, judgment, and even intuition. Pilots have been remarkably successful in saving passengers and crew under extremely difficult conditions such as when parts of their aircraft fall off (the top of the fuselage peels off) or multiply-redundant critical controls fail (no rudder control). Computers cannot be programmed to display judgment. They can only be programmed to display judgment-like behavior under conditions that have already been anticipated. UAVs should not be allowed to fly over people's houses until they are at least smart enough to turn on their own fuel supply.

[On Apr. 25, 2006 the Predator UAV being used by the U.S. Customs and Border Protection agency to patrol the border crashed in Nogales, Ariz. According to the NTSB report (NTSB Identification CHI06MA121) when the remote pilot switched from one console to another the Predator was inadvertently commanded to shut off its fuel supply and "With no engine power, the UAV continued to descend below line-of-site communications and further attempts to re-establish contact with the UAV were not successful." In other words, the Predator crashed because the system did not warn the remote pilot he had turned off the fuel supply and it was not smart enough to turn its fuel supply back on. [Ref. 40]]

An autonomous UAV assumes the computer program has no bugs.

Complex computer programs always have bugs no matter how brilliant or motivated the programmer(s). As an example, look at almost every computer program ever written.

An autonomous Unmanned Combat Aerial Vehicle (UCAV) will have little chance against one flown by an experienced pilot using Synthetic Vision until Artificial Intelligence produces a sentient, conscious

Being. At that point, all bets will be off because a superior sentient artificial Being may decide that war is stupid and refuse to participate. It may also decide that humans are obsolete or are fit only to be its slaves.

I propose yearly fly-offs:

1. A UCAV flown and fought autonomously against an F-22 (or F-35).
2. A UCAV flown and fought by a human pilot using synthetic vision against an F-22 (or F-35).
3. A UCAV flown and fought by a human pilot using synthetic vision against a UCAV flown and fought autonomously.

And that is the future of Unmanned Aerial Systems.

References

Reference 1 - *Synthetic Vision Technology for Unmanned Systems: Looking Back and Looking Forward* by Jeff Fox, Michael Abernathy, Mark Draper and Gloria Calhoun, AUVSI's **Unmanned Systems**, December 2008, pages 27-28.

This article has been reproduced with the permission of the Association for Unmanned Vehicle Systems International (AUVSI), which is the world's largest non-profit organization devoted exclusively to advancing the unmanned systems community. AUVSI, with members from government organizations, industry and academia, is committed to fostering, developing, and promoting unmanned systems and related technologies. <http://www.auvsi.org/>

PDF: http://www.jmargolin.com/svr/refs/ref01_auvsi.pdf

For the purposes of this response the article has been converted to text and the paragraphs have been numbered for easy reference: http://www.jmargolin.com/svr/refs/ref01_auvsi.htm

Reference 2 – U.S. Patent 5,593,114 **Synthetic Vision Automatic Landing System** issued January 14, 1997 to Ruhl (Assignee McDonnell Douglas Corporation).

Html copy at USPTO Patent Database:

<http://patft.uspto.gov/netacgi/nph->

[Parser?Sect1=PTO1&Sect2=HITOFF&d=PALL&p=1&u=%2Fnetacgi%2FPTO%2Fsrchnum.htm&r=1&f=G&l=50&s1=5,593,114.PN.&OS=PN/5,593,114&RS=PN/5,593,114](http://patft.uspto.gov/netacgi/nph-Parser?Sect1=PTO1&Sect2=HITOFF&d=PALL&p=1&u=%2Fnetacgi%2FPTO%2Fsrchnum.htm&r=1&f=G&l=50&s1=5,593,114.PN.&OS=PN/5,593,114&RS=PN/5,593,114)

PDF copy (complete with drawings): http://www.jmargolin.com/svr/refs/ref02_5593114.pdf

Reference 3 - **Synthetic Vision Technology Demonstration, Volume 1 of 4, Executive Summary**; Synthetic Vision Program Office Federal Aviation Administration; Malcolm A. Burgess, FAA; Terence Chang, TRW; Dale E. Dunford, USAF; Roger H. Hoh, Hoh Aeronautics; Walter F. Home, GTRI; Richard F. Tucker, TRW; December 1993. <http://www.dtic.mil/srch/doc?collection=t2&id=ADA280564>

Mirrored Copy: http://www.jmargolin.com/svr/refs/ref03_old_faa_1993.pdf

Reference 4 – **Multi-Crew Pictorial Format Display Evaluation**; AFWAL-TR-87-3047; T.C. Way, R.L. Martin, J.G. Gilmour, M.E. Hornsby, R.E. Edwards; Final Report For Period May 1984 – January 1987, Boeing Military Airplane Company, February 1987. <http://handle.dtic.mil/100.2/ADA189349>

Mirrored copy: http://www.jmargolin.com/svr/refs/ref04_pictorial_format.pdf

Reference 5 – **FAA current definition of Synthetic Vision**

FAA Title 14 Part 1

The FAA definition of synthetic vision from: <http://ecfr.gpoaccess.gov/cgi/t/text/text-idx?c=ecfr&sid=41b1c51ea8ec4c9d1c5ebb94bbf28138&rgn=div8&view=text&node=14:1.0.1.1.1.0.1.1&idno=14>

Mirrored Copy: http://www.jmargolin.com/svr/refs/ref05_faa.pdf

Title 14: Aeronautics and Space**PART 1—DEFINITIONS AND ABBREVIATIONS**

Synthetic vision means a computer-generated image of the external scene topography from the perspective of the flight deck that is derived from aircraft attitude, high-precision navigation solution, and database of terrain, obstacles and relevant cultural features.

Synthetic vision system means an electronic means to display a synthetic vision image of the external scene topography to the flight crew.

Reference 6 – FAA Synthetic Vision is based on the use of a Digital Elevation Database

FAA SV Issues- Part 23 Position

http://www.faa.gov/aircraft/air_cert/design_approvals/transport/media/Pt23ApproachSlides.pdf

Mirrored Copy: http://www.jmargolin.com/svr/refs/ref06_Pt23ApproachSlides.pdf

Federal Aviation Administration Part 23 Synthetic Vision Approval Approach

Presentation to: FAA Synthetic Vision Workshop

Name: Lowell Foster

Date: Feb 14, 2006

Page 13:

SV Issues - Part 23 Position**Terrain Data Confidence Issues Cont.**

- Complete database accuracy impossible to validate
- **Everyone gets their data from the same original source**
- Manufacturers are doing everything possible to verify the current data is accurate, but that is really just a confidence builder

If accuracy of data base must be validated then SV is unapproveable.

Page 14:

PositionRisk Management / Mitigation of Terrain Uncertainties

02203

- No operational credit for SV –current minimums still apply
- Significant safety benefits possible –outweighs what we consider minimal risk
- Experience -large data base errors to date have been easy to recognize and report –very visible on PFD and map display
- Small data base errors such as an elevation point are likely to be insolated, so exposure to a misleading information situation is considered small
- Current resolution tends to round-up the elevation data** so that small errors are not as significant and on the conservative side

Reference 7 – Digital Elevation Model: <http://data.geocomm.com/dem/>

Mirrored Copy: http://www.jmargolin.com/svr/refs/ref07_usgs_dem.pdf

The USGS Digital Elevation Model (DEM) data files are digital representations of cartographic information in a raster form. DEMs consist of a sampled array of elevations for a number of ground positions at regularly spaced intervals. These digital cartographic/geographic data files are produced by the U.S. Geological Survey (USGS) as part of the National Mapping Program and are sold in 7.5-minute, 15-minute, 2-arc-second (also known as 30-minute), and 1-degree units. The 7.5- and 15-minute DEMs are included in the large scale category while 2-arc-second DEMs fall within the intermediate scale category and 1-degree DEMs fall within the small scale category - (Source: USGS)

Reference 8 – Digital Elevation Database improved by a Space Shuttle mission.

<http://spaceflight.nasa.gov/shuttle/archives/sts-99/>

Mirrored Copy: http://www.jmargolin.com/svr/refs/ref08_sts99.pdf

STS-99 Crew Works in Shifts to Complete Mapping Mission

Endeavour's international crew of seven spent 11 days in orbit during February 2000 mapping the Earth's surface with radar instruments.

•
•
•

Space Shuttle Endeavour Maps the World in Three Dimensions

The main objective of STS-99 was to obtain the most complete high-resolution digital topographic database of the Earth.

The Shuttle Radar Topography Mission, or SRTM, was an international project spearheaded by the National Imagery and Mapping Agency and NASA, with participation of the German Aerospace Center, DLR. SRTM consisted of a specially modified radar system that flew onboard

the space shuttle during STS-99. This radar system gathered data that produced unrivaled 3-D images of the Earth's surface.

Reference 9 – Honeywell IFPD Synthetic Vision System

http://www.honeywell.com/sites/portal?page=ipfd_primus&smap=aerospace&theme=T5

Mirrored Copy: http://www.jmargolin.com/svr/refs/ref09_honeywell.pdf

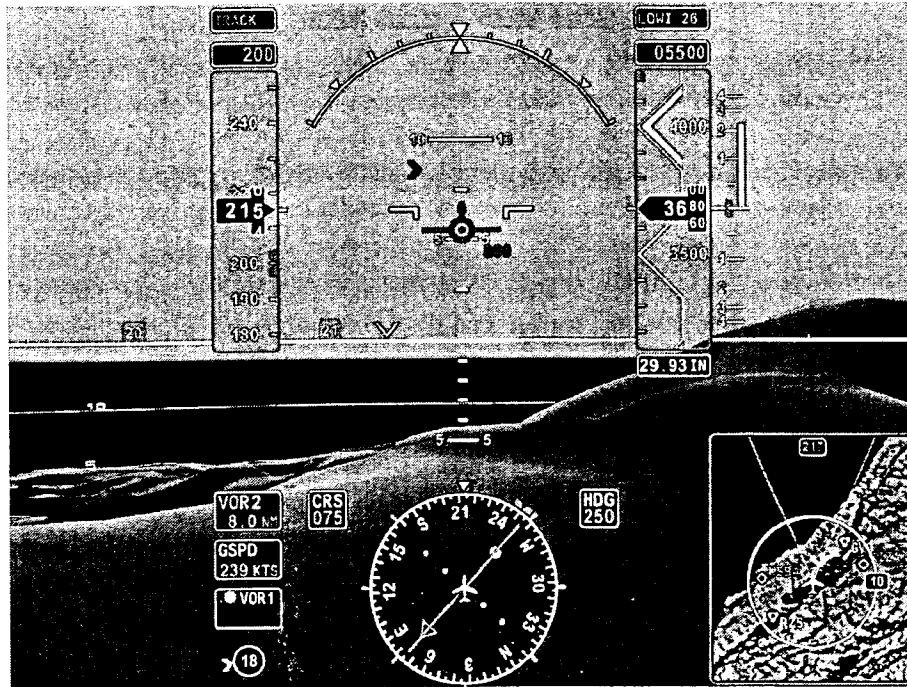
**Reference 10 - NASA description of the HiMAT project:**

<http://www.nasa.gov/centers/dryden/news/FactSheets/FS-025-DFRC.html>

Mirrored Copy: http://www.jmargolin.com/svr/refs/ref10_nasa_himat.pdf

Reference 11 - Simulator Evaluation of a Remotely Piloted Vehicle Lateral Landing Task Using a Visual Display, Shahan K. Sarrafian

NASA Technical Memorandum 84916 (May 1984):

http://www.nasa.gov/centers/dryden/pdf/87968main_H-1205.pdf

http://www.jmargolin.com/svr/refs/ref11a_sarrafian.pdf

NASA Technical Memorandum 85903 (August 1984):

http://www.nasa.gov/centers/dryden/pdf/87986main_H-1246.pdf

http://www.jmargolin.com/svr/refs/ref11b_sarrafian.pdf

I converted this article to text in order to make it easier to search and to quote from.

http://www.jmargolin.com/svr/refs/ref11c_sarrafian.doc . The downloaded PDF file is the controlling version.

Reference 12 - NASA Aviation NavigationTutorial: <http://virtualskies.arc.nasa.gov/navigation/tutorial/tutorial3.html>Mirrored copy: http://www.jmargolin.com/svr/refs/ref12_nasa_ils.pdf**Reference 13 – THE ROLE OF SIMULATION IN THE DEVELOPMENT AND FLIGHT TEST OF THE HIMAT VEHICLE**, M. B. Evans and L. J. Schilling, NASA-TM-84912, April 1984http://www.nasa.gov/centers/dryden/pdf/87962main_H-1190.pdfMirrored Copy: http://www.jmargolin.com/svr/refs/ref13_evans_schilling.pdf

From PDF page 13:

Visual Landing Aid

Actual. - Cues to the pilot during landing included the cockpit instruments, ILS/glideslope error indicators, television transmission from the vehicle, calls on the radio from the chase pilot, and space-positioning calls from the flight-test engineer.

Simulation model. - For most of the program, the landing cues for the pilot in a HiMAT simulation included only the instruments, mapboards, and the ILS/glideslope error indicators. Although these are all valid cues, they could not achieve the same effect as the television transmission used in actual flight. During flight, as soon as the pilot can identify the runway, his scan focuses more on the television picture and less on the cockpit instruments. To help alleviate this lack of fidelity in the simulation, a display of the runways on the dry lakebed was developed on a recently purchased Evans and Sutherland Graphics System.

Reference 14 - Visual-Proprioceptive Cue Conflicts in the Control of Remotely Piloted Vehicles, Reed, 1977, AFHRL-TR-77-57<http://www.dtic.mil/srch/doc?collection=t2&id=ADA049706><http://handle.dtic.mil/100.2/ADA049706>Mirrored Copy: http://www.jmargolin.com/svr/refs/ref14_reed.pdf

Page 5 (PDF page 8):

VISUAL PROPRIOCEPTIVE CUE CONFLICTS IN THE CONTROL OF REMOTELY PILOTED VEHICLES

I. INTRODUCTION

An investigation was made of operator tracking performance under conditions of visual proprioceptive conflict. (The term *proprioception* as used here refers to sensations arising from the receptors of the nonauditory labyrinth of the inner ear and from muscles, tendons, and joints. Kinesthesia refers to sensations of movement arising from the receptors other than the nonauditory labyrinth.) The experimental scenario is described as follows: An operator is asked to maneuver a remotely piloted vehicle (RPV) from an airborne control station (a mother ship). This station is equipped with a television monitor, control stick, and other controls and displays necessary to maneuver the RPV through a specified

course. The RPV, containing a television camera mounted in its nose, relays an image of the terrain to be displayed on the television monitor in the control station. Thus, the visual scene displayed to the operator represents the scene viewed by the camera. The task of the operator is to use the controls and displays to "fly" the RPV in much the same way he would fly a conventional aircraft.

The scenario is complicated by several factors. First, the visual inputs to the operator from the RPV are independent of the motion inputs from the control station. Thus, the operator will experience motion cues that are uncorrelated with the visual inputs received from the RPV. Second, while traditional pilot training programs operate on the philosophy that proprioceptive cues provided by the motion of the aircraft should be disregarded, research has shown that these cues are compelling, not easily ignored, and may improve performance when used in training simulators (see, for example, Borlace, 1967; Cohen, 1970; Douvillier, Turner, McLean, & Heinle, 1960; Fedderson, 1961; Huddleston & Rolfe, 1971; Rathert, Creer, & Douvillier, 1959; Ruocco, Vitale, & Benfari, 1965). The task simulated in the experiment presented here, however, required that the RPV operator disregard sensations of motion in order to maintain adequate performance. Under conditions of visual-proprioceptive conflict (as when the mother ship and/or the RPV are in turbulence) the stereotypic responses of pilots to correct angular accelerations will be inappropriate.

The objectives of the experiment were to obtain data applicable to the following.

1. The relative difficulty of controlling an RPV from an airborne station under different visual-motion combinations (e.g., visual-motion combinations that produce conflict, or no conflict).
2. The relative ability of pilots, navigators, and nonrated Air Force officers to operate an RPV from an airborne station (i.e., the effect of previous experience).
3. The differential effects of experience on the acquisition of skills necessary to operate an RPV.
4. Selection and training of potential RPV operators.
5. The need for motion in RPV training simulators.

II. METHOD

Simulation System

This research utilized the Simulation and Training Advanced Research System (STARS) facility of the Advanced Systems Division, Air Force Human Resources Laboratory, Wright Patterson Air Force Base, Ohio. The equipment consisted of an operator station mounted on a motion platform, hydraulic pump, terrain model, television camera and optical probe, experimenter station, and a Sigma 5 digital computer. A brief description of the hardware system is presented as follows.

Operator station. The operator station, illustrated in Figure 1, was designed to simulate the environment of an airborne control station. This station contained a television monitor that provided visual images relayed to h from a simulated RPV. These visual images were generated from a television camera and optical probe, which viewed the terrain model. The path followed by the camera and probe over the terrain model was commensurate with the vehicle flight path as determined by control stick

inputs provided by the subject. Since the control stick and visual system were independent of the motion platform, the capability existed for the subject to

5

[Figure 1. Operator station mounted on motion platform. *{not usable}*]

maneuver the simulated RPV under various environmental conditions. This arrangement permitted the introduction of conditions in which the RPV alone, the airborne station alone, or both, were under air turbulence.

The subject sat in an aircraft-type seat directly facing a 14- by 11-inch (35.6 by 27.9 cm) television monitor, which was mounted in a center sectional panel of the operator console. The distance between the subject's eyes and the center of the television screen was 28 inches (71.1 cm). The viewing angle subtended 28.07° in the lateral plane and 22.23° in the vertical plane of the monitor. An altimeter, altitude warning light, and an attitude director indicator (ADI) were mounted on a flat sectional panel to the left of the subject and at an angle of 45° from the center panel (See Figure 2). The altimeter was a vertical straight-scaled indicator with a moving pointer that provided altitude readings in feet above sea level. An amber altitude warning light flashed whenever the simulated RPV altitude dropped to a level, below 180 feet (54.9 m), remained on whenever altitude exceed 1,000 feet (304.8 m) and was off between 180 and 1,000 feet.

A 6-inch (15.2 cm) side-arm rate control stick was mounted on the right-hand side console armrest (see Figure 2). The control was a spring-centered stick with a dual-axis (fee positioning) capability that required 4 ounces, (113.4 g) breakout force. The same amount of force was needed to hold the stick at full deflection. The range of deflection on both lateral (right - left) and longitudinal (fore - aft) stick was 0 to 25° (henceforth referred to as 0 to 100 percent deflection).

In addition, the operator station contained a foot switch to allow the subject to communicate with the experimenters. White noise was input to the subject's headset to mask external disturbances. The aircraft seat was equipped with a standard harness and lapbelt to protect the subject. An air conditioner maintained the station at 70° F (21.1° C). Finally, incident illumination was at an average of .37 footcandles at eye level.

6

[Figure 2. Operator station instruments and control stick. *{not usable}*]

Motion system. The operator station was mounted on a motion platform that provided onset cues in two degrees of freedom of angular acceleration. Roll onset cues were provided by tilting the simulator about the longitudinal axis (i.e., the X axis) and pitch onset cues were provided by tilting the simulator about the lateral axis (i.e., the 'Y' axis). Motion was achieved by actuation of hydraulic cylinders mounted under the 9- by 8-foot (2.74 by 2.4 m) simulator platform, as shown in Figure 1.

Visual system. The visual system consisted of a three-dimensional terrain model (a modified SMK-23 Visual Simulator, The Singer Company), television camera and optical probe, and three monochromatic television monitors. The terrain model provided "real-world ground cues for visual tracking over the surface. The real-world to terrain model scale was 3,000:1 and represented a six by twelve-mile (9.65 by 19.3 km) area. The model was mounted on an endless belt that was servo-driven to represent the continuous changes in scene as the simulated RPV traveled along north-south directions. A television camera viewed the terrain model through an optical probe that contained a servoed mechanical

assembly to permit the introductions of heading, roll, and pitch. Both the camera and probe were mounted on a servo-driven carriage system that moved across the terrain model to simulate movement of the RPV along east-west directions and in and out to simulate altitude changes. The field of view represented on the television monitor subtended a viewing angle of 50° horizontally and 38° vertically over the terrain model. One television monitor was mounted in the operator station and the other two were located in the experimenter station. All three monitors had a 1,000-line resolution vertically.

Experimenter station. The experimenter station contained the equipment necessary to monitor the status of the hardware/software and control activities of the subject, and to setup the various stimulus conditions. This station was manned by two experimenters. The task of the first was to prepare the system for operation, insure that all hardware was operating effectively and reliably prior and during the experiment, and set up the conditions for all experimental trials in accordance with a prepared check list. The task of the second experimenter was to determine the appropriate time for introducing specific stimuli to the subject. When certain criteria were met, the experimenter pressed a discrete hand-held insert button to initiate a stimulus trial.

Computer system and interfaces. A Sigma 5 digital computer was used to drive the peripheral equipment, and to record data during experimental runs. Resident software consisted of a real-time aerodynamic mathematical model, executive routine, and data recording programs. The

7

Reference 15 - Lunar Driving Simulator History

<http://www.knology.net/~skeetv/SimHist3.html>

Mirrored copy: http://www.jmargolin.com/svr/refs/ref15_lunar_driving_history.pdf

Reference 16 - Evans & Sutherland Picture System:

Short Brochure: <http://www.computerhistory.org/brochures/companies.php?alpha=d-f&company=com-42b9d8b7f4191>

Full Brochure: http://archive.computerhistory.org/resources/text/Evans_Sutherland/EvansSutherland.3D.1974.102646288.pdf

Mirrored copy:

Short Brochure: http://www.jmargolin.com/svr/refs/ref16_esps_s.pdf

Full Brochure: http://www.jmargolin.com/svr/refs/ref16_esps_f.pdf

Reference 17 – RC AeroChopper Review: <http://www.atarimagazines.com/startv3n9/rcaerochopper.html>

Mirrored Copy: http://www.jmargolin.com/svr/refs/ref17_aerochopper.pdf

Reference 18 – Microsoft Flight Simulator

Microsoft Flight Simulator 5.1 Screen Shot:

http://www.jmargolin.com/svr/refs/ref18_fs5_1_screenshot.pdf

Microsoft Flight Simulator History: http://www.jmargolin.com/svr/refs/ref18_fs_history.pdf

Reference 19 – Microsoft Flight Simulator's first use of terrain points:

[http://www.flightsim.com/cgi/kds?\\$/=main/review/fs2000.htm](http://www.flightsim.com/cgi/kds?$/=main/review/fs2000.htm)

Mirrored copy: http://www.jmargolin.com/svr/refs/ref19_fs_first.pdf

Reference 20 – News releases from RTI (Research Triangle Institute), Avidyne, AvroTec, and NASA announcing NASA had selected those companies to develop a synthetic vision system for General Aviation. www.jmargolin.com/svr/refs/ref20_nasa1999.pdf

Reference 21: NASA press release, May 13, 1999, <http://quest.nasa.gov/aero/news/05-13-99.txt>

Mirrored copy: http://www.jmargolin.com/svr/refs/ref21_nasa_pr.pdf

Michael Braukus

Headquarters, Washington, DC

(Phone: 202/358-1979)

May 13, 1999

Kathy Barnstorff

Langley Research Center, Hampton, VA

(Phone: 757/864-9886)

RELEASE: 99-59

SYNTHETIC VISION COULD HELP PILOTS STEER CLEAR OF FATALITIES

NASA and industry are developing revolutionary cockpit displays to give airplane crews clear views of their surroundings in bad weather and darkness, which could help prevent deadly aviation accidents.

Limited visibility is the greatest factor in most fatal aircraft accidents, said Michael Lewis, director of the Aviation Safety Program at NASA's Langley Research Center in Hampton, VA. NASA has selected six industry teams to create Synthetic Vision, a virtual-reality display system for cockpits, offering pilots an

electronic picture of what's outside their windows, no matter the weather or time of day.

"With Global Positioning Satellite signals, pilots now can know exactly where they are," said Lewis. "Add super-accurate terrain databases and graphical displays and we can draw three-dimensional moving scenes that will show pilots exactly what's outside. The type of accidents that happen in poor visibility just don't happen when pilots can see the terrain hazards ahead."

The NASA Aviation Safety Program envisions a system that would use new and existing technologies to incorporate data into displays in aircraft cockpits. The displays would show hazardous terrain, air traffic, landing and approach patterns, runway surfaces and other obstacles that could affect an aircraft's flight.

Industry teams submitted 27 proposals in four categories: commercial transports and business jets, general aviation aircraft, database development and enabling technologies. NASA and researchers from the Federal Aviation Administration and Department of Defense evaluated the proposals' technical merit, cost and feasibility.

NASA has committed \$5.2 million that will be matched by \$5.5 million in industry funds to advance Synthetic Vision projects over the next 18 months. More money is expected to be designated later to accelerate commercialization and make some systems available within four to six years.

Among the team leaders selected for the first phase of the program are: Rockwell Collins, Inc., Cedar Rapids, IA; AvroTec, Inc., Portland, OR; Research Triangle Institute, Research Triangle Park, NC; Jeppesen-Sanderson, Inc., Englewood, CO; the Avionics Engineering Center of Ohio University, Athens, OH; and Rannoch Corporation, Alexandria, VA.

Rockwell Collins, Inc. will receive funds to develop synthetic vision for airliners and business jets. The AvroTec, Inc. and Research Triangle Institute groups will use their awards to create technologies for a general-aviation synthetic vision system. A team led by Jeppesen-Sanderson, Inc. will receive funds to develop terrain database requirements and system approaches. The Avionics Engineering Center of Ohio University and Rannoch Corporation will use their awards to design specific component technologies for Synthetic Vision.

The Aviation Safety Program is a partnership with the FAA, aircraft manufacturers, airlines and the Department of Defense.

This partnership supports the national goal announced by President Clinton to reduce the fatal aircraft accident rate by 80 percent in 10 years and by 90 percent over 25 years.

Because of advances in the last 40 years, commercial airliners are already the safest of all major forms of transportation. But with an accident rate that has remained relatively constant in the last decade and air traffic expected to triple over the next 20 years, the U.S. government wants to prevent a projected rise in the number of aircraft accidents.

For a complete list of industry teams please check the Internet at:

http://oea.larc.nasa.gov/news_rels/1999/May99/99-025.html

- end -

Reference 22 – Virtual Cockpit Window" for a Windowless Aerospacecraft, NASA Tech Briefs, January 2003, page 40. <http://www.nasatech.com/Briefs/Jan03/MS23096.html>
Mirrored Copy: http://www.jmargolin.com/svr/refs/ref22_nasa_techbriefs.pdf

"Virtual Cockpit Window" for a Windowless Aerospacecraft

Wednesday, January 01 2003

A software system processes navigational and sensory information in real time to generate a three-dimensional-appearing image of the external environment for viewing by crewmembers of a windowless aerospacecraft. The design of the particular aerospacecraft (the X-38) is such that the addition of a real transparent cockpit window to the airframe would have resulted in unacceptably large increases in weight and cost.

When exerting manual control, an aircrew needs to see terrain, obstructions, and other features around the aircraft in order to land safely. The X-38 is capable of automated landing, but even when this capability is utilized, the crew still needs to view the external environment: From the very beginning of the United States space program, crews have expressed profound dislike for windowless vehicles. The well-being of an aircrew is considerably promoted by a three-dimensional view of terrain and obstructions. The present software system was developed to satisfy the need for such a view. In conjunction with a computer and display equipment that weigh less than would a real transparent window, this software system thus provides a "virtual cockpit window."

The key problem in the development of this software system was to create a realistic three-dimensional perspective view that is updated in real time. The problem was solved by building upon a pre-existing commercial program — LandForm C3 — that combines the speed of flight-simulator software with the power of geographic-information-system software to generate real-time, three-dimensional-appearing displays of terrain and other features of flight environments. In the development of the present software, the pre-existing program was modified to enable it to utilize real-time information on the position and attitude of the aerospacecraft to generate a view

of the external world as it would appear to a person looking out through a window in the aerospacecraft. The development included innovations in realistic horizon-limit modeling, three-dimensional stereographic display, and interfaces for utilization of data from inertial-navigation devices, Global Positioning System receivers, and laser rangefinders. Map and satellite imagery from the National Imagery and Mapping Agency can also be incorporated into displays.

After further development, the present software system and the associated display equipment would be capable of providing a data-enriched view: In addition to terrain and obstacles as they would be seen through a cockpit window, the view could include flight paths, landing zones, aircraft in the vicinity, and unobstructed views of portions of the terrain that might otherwise be hidden from view. Hence, the system could also contribute to safety of flight and landing at night or under conditions of poor visibility.

In recent tests, so precise was the software modeling that during the initial phases of the flight the software running on a monitor beside the video camera produced nearly identical views.

This work was done by Michael F. Abernathy of Rapid Imaging Software, Inc., for Johnson Space Center. For further information, please contact Michael F. Abernathy, Rapid Imaging Software, Inc., 1318 Ridgcrest Place S.E., Albuquerque, NM 87108. MSC-23096.

Reference 23 – Press Release from Rapid Imaging Software, Inc. (<http://www.landform.com/pages/PressReleases.htm>) which states (near the bottom of the page):
Mirrored copy: http://www.jmargolin.com/svr/refs/ref23_ris.pdf



On December 13th, 2001, Astronaut Ken Ham successfully flew the X-38 from a remote cockpit using LandForm VisualFlight as his primary situation awareness display in a flight test at Edwards Air Force Base, California. This simulates conditions of a real flight for the windowless spacecraft, which will eventually become NASA's Crew Return Vehicle for the ISS. We believe that this is the first test of a hybrid synthetic vision system which combines nose camera video with a LandForm synthetic vision display. Described by astronauts as "the best seat in the house", the system will ultimately make space travel safer by providing situation awareness during the landing phase of flight.

Reference 24 – Description of Path-in-the-Sky Contact Analog Piloting Display, Charles E. Knox and John Leavitt, October 1977, NASA Technical Memorandum 74057
http://ntrs.nasa.gov/archive/nasa/casi.ntrs.nasa.gov/19780002119_1978002119.pdf

Mirrored Copy: http://www.jmargolin.com/svr/refs/ref24_knox.pdf

Reference 25 - "The Electronic Terrain Map: A New Avionics Integrator", Small, D.M. USAF, Avionics Laboratory, Wright-Patterson AFB, OH, AIAA-1981-2289. In: Digital Avionics Systems Conference, 4th, St. Louis, MO, November 17-19, 1981, Collection of Technical Papers. (A82-13451 03-04) New York, American Institute of Aeronautics and Astronautics, 1981, p. 356-359.
http://www.jmargolin.com/svr/refs/ref25_small.pdf

Converted to text using OCR: http://www.jmargolin.com/svr/refs/ref25_small.html

Reference 26 - This is part of the Washington Sectional Aeronautical Chart, Scale 1:500,000 55th Edition, published March 3, 1994 by U.S. Department of Commerce National Oceanic and Atmospheric Administration National Ocean Service.

Map: http://www.jmargolin.com/svr/refs/ref26_pmap1.pdf

Washington Legend showing paper map symbology: http://www.jmargolin.com/svr/refs/ref26_pmap2.pdf

Reference 27 - **Using Synthetic Images to Register Real Images with Surface Models**; Horn, Berthold K.P.; Bachman, Brett L. ; August 1977.

MIT DSpace: <http://hdl.handle.net/1721.1/5761>

Mirrored Copy: http://www.jmargolin.com/svr/refs/ref27_horn.pdf

Abstract: A number of image analysis tasks can benefit from registration of the image with a model of the surface being imaged. Automatic navigation using visible light or radar images requires exact alignment of such images with digital terrain models. In addition, automatic classification of terrain, using satellite imagery, requires such alignment to deal correctly with the effects of varying sun angle and surface slope. Even inspection techniques for certain industrial parts may be improved by this means.

Reference 28 - U.S. Patent 3,328,795 **Fixtaking Means and Method** issued June 27, 1967 to Hallmark.

USPTO Database (Does not have http version): <http://patft.uspto.gov/netacgi/nph-Parser?Sect1=PTO1&Sect2=HITOFF&d=PALL&p=1&u=%2Fnethtml%2FPTO%2Fsrchnum.htm&r=1&f=G&l=50&s1=3,328,795.PN.&OS=PN/3,328,795&RS=PN/3,328,795>

PDF Version: http://www.jmargolin.com/svr/refs/ref28_3328795.pdf

Reference 29 - U.S. Patent 4,347,511 **Precision navigation apparatus** issued August 31, 1982 to Hofmann, et al.

From USPTO: <http://patft.uspto.gov/netacgi/nph-Parser?Sect1=PTO1&Sect2=HITOFF&d=PALL&p=1&u=%2Fnethtml%2FPTO%2Fsrchnum.htm&r=1&f=G&l=50&s1=4,347,511.PN.&OS=PN/4,347,511&RS=PN/4,347,511>

PDF Version: http://www.jmargolin.com/svr/refs/ref29_4347511.pdf

Reference 30 – I don't know if Terrain Referenced Navigation works over Kansas, but I know Kansas is flat. From: <http://www.guardian.co.uk/education/2003/sep/25/research.highereducation2>

This year, for instance, three geographers compared the flatness of Kansas to the flatness of a pancake. They used topographic data from a digital scale model prepared by the US Geological Survey, and they purchased a pancake from the International House of Pancakes. If perfect flatness were a value of 1.00, they reported, the calculated flatness of a pancake would be 0.957 "which is pretty flat, but far from perfectly flat". Kansas's flatness however turned out to be 0.997, which they said might be described, mathematically, as "damn flat".

Mirrored Copy: http://www.jmargolin.com/svr/refs/ref30_kansas.pdf

Reference 31 - U.S. Patent 4,660,157 **Real time video perspective digital map display method** issued April 21, 1987 to Beckwith, et al.

USPTO (html): <http://patft.uspto.gov/netacgi/nph-Parser?Sect1=PTO1&Sect2=HITOFF&d=PALL&p=1&u=%2Fnethtml%2FPTO%2Fsrchnum.htm&r=1&f=G&l=50&s1=4,660,157.PN.&OS=PN/4,660,157&RS=PN/4,660,157>

PDF: http://www.jmargolin.com/svr/refs/ref31_4660157.pdf

Reference 32 – U.S. Patent 5,179,638 **Method and apparatus for generating a texture mapped perspective view** issued January 12, 1993 to Dawson, et al.

USPTO (html): <http://patft.uspto.gov/netacgi/nph-Parser?Sect1=PTO1&Sect2=HITOFF&d=PALL&p=1&u=%2Fnethtml%2FPTO%2Fsrchnum.htm&r=1&f=G&l=50&s1=5,179,638.PN.&OS=PN/5,179,638&RS=PN/5,179,638>

PDF: http://www.jmargolin.com/svr/refs/ref32_5179638.pdf

Reference 33 - U.S. Patent 4,884,220 **Address Generation with Variable Scan Patterns** issued November 28, 1989 to Dawson et al.

USPTO (html): <http://patft.uspto.gov/netacgi/nph-Parser?Sect1=PTO1&Sect2=HITOFF&d=PALL&p=1&u=%2Fnethtml%2FPTO%2Fsrchnum.htm&r=1&f=G&l=50&s1=4,884,220.PN.&OS=PN/4,884,220&RS=PN/4,884,220>

PDF: http://www.jmargolin.com/svr/refs/ref33_4884220.pdf

Reference 34 - **VCASS: An Approach to Visual Simulation**, Kocian, D., 1977, Presented at the IMAGE Conference, Phoenix, Ariz., 17-18 May 77.

Available for purchase from DTIC <http://www.dtic.mil/srch/doc?collection=t2&id=ADA039999>
Mirrored Copy: http://www.jmargolin.com/svr/refs/ref34_vcass.pdf

Converted to text using OCR (with the paragraphs numbered):
http://www.jmargolin.com/svr/refs/ref34_vcass.htm

Reference 35 – The earliest known description of the invention that became U.S. Patent 5,566,073 **Pilot Aid Using A Synthetic Environment**. http://www.jmargolin.com/svr/refs/ref35_pilotdoc.pdf

Reference 36 - U.S. Patent 5,566,073 **Pilot Aid Using A Synthetic Environment** issued October 15, 1996 to Margolin

USPTO (html): <http://patft.uspto.gov/netacgi/nph-Parser?Sect1=PTO1&Sect2=HITOFF&d=PALL&p=1&u=%2Fnethtml%2FPTO%2Fsrchnum.htm&r=1&f=G&l=50&s1=5,566,073.PN.&OS=PN/5,566,073&RS=PN/5,566,073>

PDF: http://www.jmargolin.com/svr/refs/ref36_5566073.pdf

Reference 37 – U.S. Patent 5,904,724 **Method and apparatus for remotely piloting an aircraft** issued May 18, 1999 to Margolin

USPTO (html): <http://patft.uspto.gov/netacgi/nph-Parser?Sect1=PTO1&Sect2=HITOFF&d=PALL&p=1&u=%2Fnethtml%2FPTO%2Fsrchnum.htm&r=1&f=G&l=50&s1=5,904,724.PN.&OS=PN/5,904,724&RS=PN/5,904,724>

PDF: http://www.jmargolin.com/svr/refs/ref37_5904724.pdf

Reference 38 - U.S. Patent Application Publication 20080033604 **System and Method For Safely Flying Unmanned Aerial Vehicles in Civilian Airspace**

USPTO (html): <http://appft1.uspto.gov/netacgi/nph-Parser?Sect1=PTO2&Sect2=HITOFF&u=%2Fnethtml%2FPTO%2Fsearch-adv.html&r=18&p=1&f=G&l=50&d=PG01&S1=%22synthetic+vision%22&OS=%22synthetic+vision%22&RS=%22synthetic+vision%22>

PDF: http://www.jmargolin.com/svr/refs/ref38_pg3604.pdf

Reference 39 – Letter sent to Optima Technology Group by Rapid Imaging Software attorney Benjamin Allison, dated October 13, 2006. http://www.jmargolin.com/svr/refs/ref39_ris.pdf

Reference 40 - NTSB Incident Report on crash of Predator on April 25, 2006, northwest of Nogales, NM. NTSB Identification **CHI06MA121**

http://www.nts.gov/nts/brief.asp?ev_id=20060509X00531&key=%201

Mirrored Copy: http://www.jmargolin.com/svr/refs/ref40_nts.pdf

.end

02222