

2

1

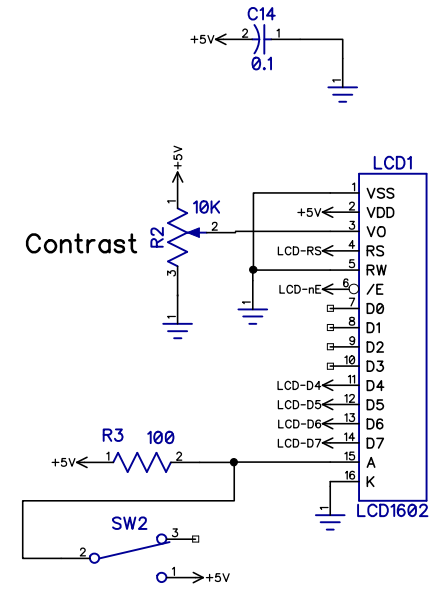

BME280 6-pin	J2 I2C Port
+3.3V	+3.3V
GND	GND
SCL	SCL
SDA	SDA
CSB	+3.3V
SDO	GND

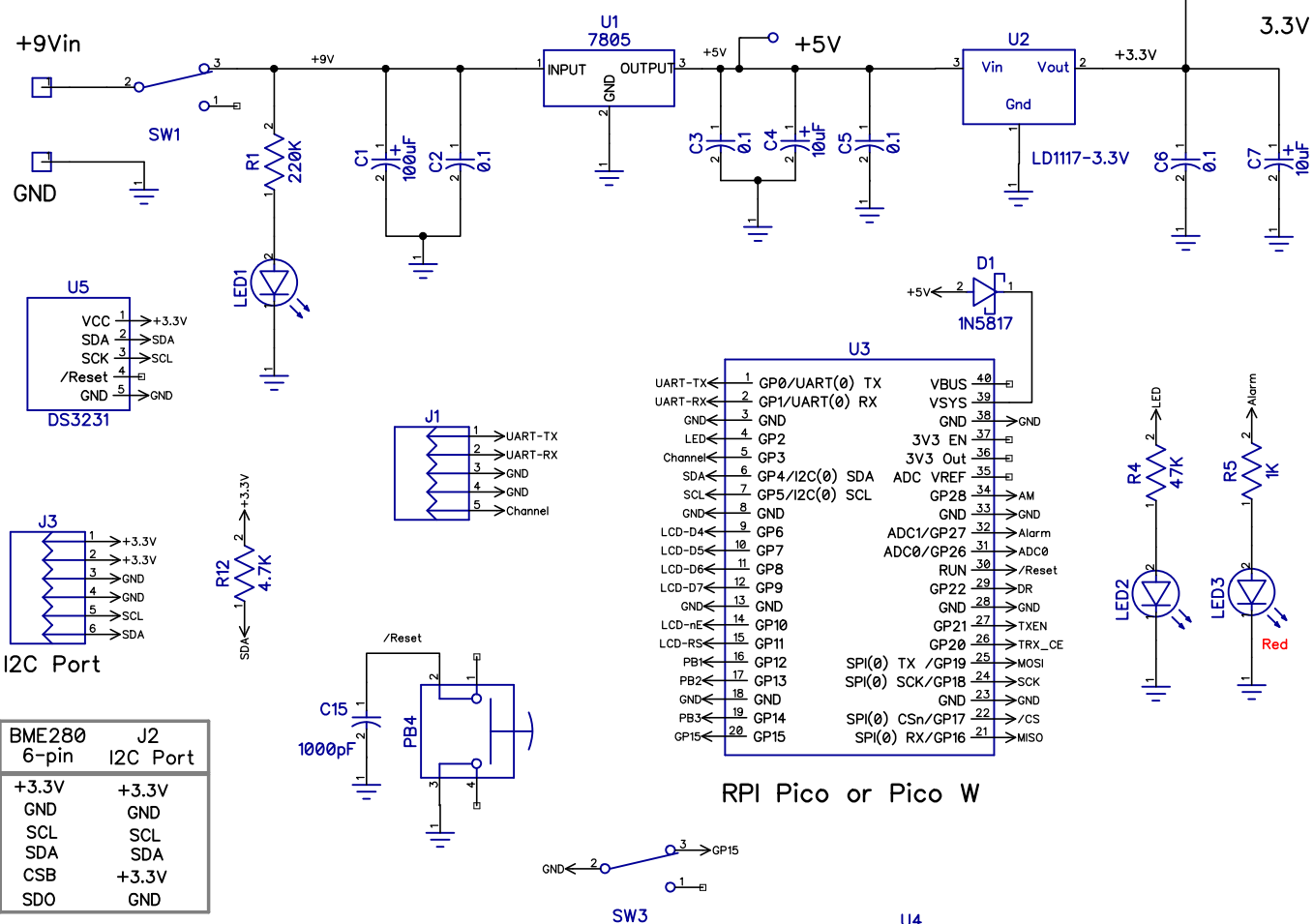
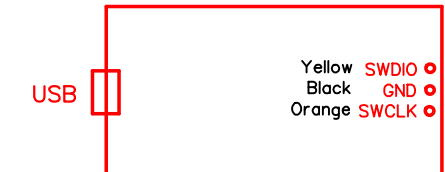

Raspberry Pi Pico/W
 Development V6
 Sheet 1 of 2
 (C) Jed Margolin 2024

2

1

